

CAPIZ STATE UNIVERSITY

ANNUAL REPORT

2022 EDITION

CAPSU CENTRAL
ADMIN. BUILDING



MOVING FORWARD

VISION

Center of Academic Excellence Delivering Quality Service to all.

MISSION

Capiz State University is committed to provide advanced knowledge and innovation; develop skills, talents and values; undertake relevant research, development and extension services; promote entrepreneurship and environmental consciousness; and enhance industry collaboration and linkages with partner agencies.

GOALS

- Globally-competitive graduates;
- Institutionalized research culture;
- Responsive and sustainable extension services;
- Maximized profit of viable agro-industrial business ventures and diversified income-generating projects;
- Effective and efficient administration.

GUIDING PRINCIPLES

As provided in the University Code, the operation of the University is guided by the following principles:

- **Academic Freedom.** The University has the right and the responsibility to exercise academic freedom. Institutional academic freedom is the freedom of the university from intervention and control in the conduct of its affairs. Individual academic freedom is the right of the teacher and the student to conduct academic and scholarship inquiry and to publish the results without prior restraint or subsequent punishment.
- **Responsibility.** As a public institution supported by public funds, the University is responsible for carrying out the basic principles laid down by the Constitution of the Philippines and the University Charter and to relate its activities and offerings to the needs of the region and the nation. Training for responsible leadership and citizenship shall be provided to those who abide by the norms of the institution to achieve their maximum potential in a society that respects human dignity to attain the common goal.
- **Academic Standards.** The University shall achieve and maintain high academic standards of instruction, research, extension, and production; and all other administrative and auxiliary activities shall be supportive of these functions.

CORE VALUES

The university shall strive to exemplify the following core values as the foundations of all actions:

- **God-Centered**
CAPSU adheres to the greatest of all commandments. The first is to Love God with all our heart, soul, and strength. The second is Love of neighbor/fellowmen as ourselves. Everything we do in CapSU is for the honor and glory of God and for the welfare of humanity.
- **Excellence**
“We excel where it counts.” In CAPSU, all our endeavors will be undertaken to the best of our ability. All services will be delivered within our “level best”. All jobs and HR advancement will be based on merit and fitness, placing the right mix of people at the right job. Performance will be characterized by refinement, brilliance and distinction.
- **Integrity**
“Honesty is the best policy.” All instruction, research, extension, and production activities are in the pursuit of truth-being defined as the knowledge of things as they are, as they were, and as they are to come. The methodologies and approaches are scientific, credible/reliable, verifiable and dedicated to the formation of honest, honorable, righteous and productive citizens of the community.
- **Transparency and Accountability**
The Agency Transparency Seal showing the simplicity, clearness, precision and intelligibility of all our services and transactions are posted on the CAPSU website: www.capsu.edu.ph. We are responsible and accountable for our actions. We must be proactive, as such, we must act rather than to be acted upon.
- **Dedication to Quality Service**
We will honor our Commitment to pursue a task to its completion, devotion to duty, and loyalty to CAPSU as an institution as summed up in the acronym, **RACE**: **R**esponsive, **A**ccessible, **C**ourteous and **E**ffective Public Service.



ABOUT THE COVER:

MOVING FORWARD

Ian B. Arcega

The COVID-19 pandemic is not only a global health crisis but also a proof of restructuring the outlooks, economic alignments, and even everyday lives. It navigates the capabilities of world leaders to see a clear future.

The duration of the pandemic recalls our ideals and aspirations. We were compelled to reimagine how to safeguard the lives and livelihoods of everyone. Even processes and systems are in turmoil. However, we collectively shed our spirit through Bayanihan. These Filipino values emanate on pre and post-pandemic. The community called for one voice: "Agility and Resiliency."

In every institution the priorities of management is for long-term and sustained survival. While others are gazing through the fog of ambiguity, thinking about how to achieve their niche once the pandemic will pass and the things return to normal. The question is, "What will be the face of the new normal?"

We need to collect our efforts in battling COVID-19. We must win to find an economically and socially viable path to the next normal by having inclusive crisis-response strategies on health, economics, and education. To accelerate and meet the demand of society. Educational institutions are moving to the hybrid way of delivering instruction, research, production, and extension services. Students can cope, but the question that challenges the institution is the state of quality. It metastasized into an escalating crisis efficiency and effectiveness. But, we need to become confident in providing a clear and inclusive solution to the impact of the pandemic in the systems and processes.

However, we Filipinos are agile and resilient. Beyond this COVID-19 pandemic, we will be able to see the future through partnership and collaboration. Also, engaging each other for the goals; exploring the capabilities of everyone by providing an immediate solution to the problem; and by this, we will excel through dark times. Indeed, beyond COVID-19, we are creating the new normal. A place that taught us to fight and prepare for the unknown.

QUALITY POLICY

CapSU is committed to be the center of academic excellence delivering quality service to all by:

Continuing innovations and quality improvements cultivating an efficient and effective environment for maximum clientele satisfaction;

Adhering to laws and regulations, global standards and environmental change requirements;

Participating in sustainable development projects for inclusive economic growth;

Showing quality outputs; and

Upholding values and integrity and nurturing talents and skills for global competitiveness.

Table of Contents

- Letter to the President of the Republic of the Philippines
- Curricular Offerings
- Brief History

01	EXECUTIVE SUMMARY
05	INSTRUCTION: BEYOND LEARNING
47	EXTERNAL AFFAIRS AND LINKAGES: BEYOND BOUNDARIES
49	RESEARCH: BEYOND INNOVATIONS
67	EXTENSION: BEYOND CALL OF DUTY
77	ADMINISTRATION & GOVERNANCE: BEYOND EFFICIENCY
87	PRODUCTION: BEYOND CRISIS
95	SUMMARY OF BOARD RESOLUTIONS

- Organizational Structure
- Board of Regents
- Key Officials
- Production Team

Quadro-Dimension Functions of the University



CAPIZ STATE UNIVERSITY

2022 EDITION

ANNUAL REPORT

MOVING FORWARD



Republic of the Philippines
CAPIZ STATE UNIVERSITY

Fuentes Drive, Roxas City, Capiz, Philippines
Tel. No. (036)621-3514 Fax No. (036) 621-4337
www.capsu.edu.ph email address: admin@capsu.edu.ph

OFFICE OF THE UNIVERSITY PRESIDENT

His Excellency
PRESIDENT RODRIGO R. DUTERTE
Republic of the Philippines
Malacañan Palace
Manila

Through The Honorable:

DR. J. PROSPERO E. DE VERA III
Chairman
Commission on Higher Education (CHED)
C.P. Garcia, Quezon City

President Duterte:

Mabuhay!

The Capiz State University 2022 Annual Report is humbly submitted to your office. The report highlights the notable accomplishments and significant milestones in the fourfold mandate- research, instruction, production, extension as well as linkages and governance.

Thank you and God bless.

Very truly yours,

EDITHA C. ALFON, PhD
SUC President III

CURRICULAR OFFERINGS

BURIAS CAMPUS

GRADUATE PROGRAMS

- **Doctor of Philosophy**
(Level II Re-Accredited)
Majors in: Agronomy
Animal Science
- **Master of Science**
(Level III Re-Accredited)
Majors in: Agronomy
Animal Science
- **Doctor in Public Administration**
(Level II Re-Accredited)
- **Master in Public Administration**
(Level II Re-Accredited)
- **Doctor of Education**
(Level II Re-Accredited)
Major in: Educational Management
- **Master of Arts in Education**
(Candidate)
Major in: Educational Management (Level II)
General Science (Candidate Status)
Social Science (Candidate Status)
English (PSV)
Filipino (PSV)

UNDERGRADUATE PROGRAMS

- **Bachelor of Science in Agricultural and Biosystems Engineering**
(PSV)
- **Bachelor of Science in Agriculture**
(Level III)
Majors in: Agronomy
Agri-Business
Animal Science (Passed: Areas II, V, VI)
Crop Science
Horticulture
Plant Protection
Soil Science
- **Bachelor of Science in Business Administration**
(Level II Re-Accredited)
Majors in: Financial Management
Marketing Management
- **Bachelor in Public Administration**
(Candidate)
- **Bachelor of Science in Entrepreneurship**
- **Bachelor of Elementary Education**
(Level II Re-Accredited)
- **Bachelor of Secondary Education**
(Level II Re-Accredited)
Majors in: English
Filipino
Science
Math
Social Studies
- **Bachelor of Physical Education**
(PSV)

SECONDARY LABORATORY HIGH SCHOOL

CURRICULAR OFFERINGS

PONTEVEDRA CAMPUS

GRADUATE PROGRAMS

- **Doctor of Education**
(Level III Re-Accredited)
Major in: Educational Management
- **Doctor of Philosophy**
(Level II Accredited)
Majors in: Agronomy
Animal Science
- **Doctor of Public Administration**
(Level II Accredited)
- **Master of Arts in Education**
(Level II Accredited)
Majors in: Educational Management (Level III)
English
Filipino
Mathematics
General Science (PSV)
Social Science (PSV)
- **Master in Public Administration**
(Level II Accredited)
- **Master of Science**
(Level II Accredited)
Major in: Agronomy & Animal Science
- **Bachelor of Science in Computer Science**
(Level III Re-Accredited)
- **Bachelor of Science in Agriculture**
(Level III Re-Accredited)
Majors in: Animal Science
Crop Science
- **Bachelor of Science in Business Administration**
(Level III Re-Accredited)
Majors in: Human Resource Management
Financial Management
- **Bachelor of Science in Hospitality Management**
(Level III Re-Accredited)
- **Bachelor of Science in Fisheries**
(PSV)
- **Bachelor of Physical Education (BPED)**
(PSV)

UNDERGRADUATE PROGRAMS

- **Bachelor of Science in Agricultural & Biosystems Engineering**
(Level III Re-Accredited)
- **Bachelor of Secondary Education**
Majors in: English (Level III Re-Accredited)
Filipino (Level III Re-Accredited)
Mathematics (Level III Re-Accredited)
Science (Passed: Areas II, IV)
Social Studies (Passed: Areas II, IV)
- **Bachelor of Elementary Education**
(Level III Re-Accredited)

ROXAS CITY CAMPUS

GRADUATE PROGRAMS

- **Doctor of Education**
(Level II Re-Accredited)
Major in: Industrial Education
- **Master of Science in Criminal Justice**
(Level II Accredited)
with Specialization in Criminology
- **Master of Science in Fisheries**
(PSV)
- **Master in Public Administration**
(Level II Re-Accredited)
- **Master of Arts in Education**
(Level II Accredited)
Majors in: Home Economics
Industrial Arts
MAPEH (Level I)

UNDERGRADUATE PROGRAMS

- **Bachelor of Secondary Education**
[Level II Accredited]
Majors in: English
 Filipino
 Science

- **Bachelor of Physical Education**
[Level II Re-Accredited]

- **Bachelor of Technology and Livelihood Education**
[Level II Re-Accredited]
Majors in: Home Economics
 Industrial Arts

- **Bachelor of Industrial Technology**
Majors in: Architectural Drafting Technology [Level III Re-Accredited]
 Auto Diesel technology
 Cosmetology [Level III Re-Accredited]
 Electrical Technology [Level III Re-Accredited]
 Electronics Technology [Level III Re-Accredited]
 Fashion and Apparel Technology [Level III Re-Accredited]
 Food Technology [Level III Re-Accredited]
 Heating, Ventilating, Air Condition and Refrigeration
 Technology [Level III Re-Accredited]
 Mechanical Technology
 Welding and Fabrication Technology

- **Bachelor of Science in Electrical Engineering**
[Level III Re-Accredited]

- **Bachelor of Science in Mechanical Engineering**
[Level III Re-Accredited]

- **Bachelor of Science in Architecture**
[Level II Re-Accredited]

- **Bachelor of Science in Civil Engineering**
[Level II Re-Accredited]

- **Bachelor of Science in Business Administration**
[Level II Re-Accredited]
Major in: Marketing Management

- **Bachelor of Science in Entrepreneurship**
[Level II Re-Accredited]

- **Bachelor of Science in Accountancy**
[PSV]

- **Bachelor of Public Administration**
[PSV]

SECONDARY LABORATORY HIGH SCHOOL

PILAR SATELLITE COLLEGE

- **Bachelor of Science in Hospitality Management**
[Level II Re-Accredited]

- **Bachelor of Elementary Education**
[Level II Re-Accredited]

- **Bachelor of Science in Information Technology**
[Level II Re-Accredited]

- **Bachelor of Science in Social Work**
[Level II Re-Accredited]

- **Bachelor of Science in Agriculture**
[Level II Re-Accredited]
Major in: Agronomy

- **Bachelor of Science in Business Administration**
[Level II Re-Accredited]
Majors in: Human Resource Management
 Marketing Management

SIGMA SATELLITE COLLEGE

- **Bachelor of Science in Hospitality Management**
[Level III Re-Accredited]

- **Bachelor of Science in Tourism Management**
[Level III Re-Accredited]

- **Bachelor of Technical-Vocational Teacher Education**
[PSV]
Majors in: Electrical Technology
 Automotive Technology
 Food Service Management
 Garments, Fashion and Design

CURRICULAR OFFERINGS

TAPAZ SATELLITE COLLEGE

- **Bachelor of Science in Agriculture**
(Level III Re-Accredited)
Majors in: Animal Science
Crop Science
- **Bachelor of Elementary Education**
(Level III Re-Accredited)
- **Bachelor of Secondary Education**
(PSV)
Major in: Mathematics

MAMBUSAO SATELLITE COLLEGE

- **Bachelor of Science in Computer Science**
(Level II Re-Accredited)
- **Bachelor of Science in Office Administration**
(Level II Re-Accredited)
- **Bachelor of Science in Food Technology**
(Level II Re-Accredited)
- **Bachelor of Arts in English Language**
(Level II Re-Accredited)
Major in: English

DUMARAO SATELLITE COLLEGE

- **Doctor of Veterinary Medicine**
(Level II Re-Accredited)
- **Bachelor of Elementary Education**
(Level II Re-Accredited)
- **Bachelor of Secondary Education**
Major in: Social Studies (Level II Accredited)
Science (PSV)
- **Bachelor of Science in Criminology**
(Level II Accredited)
- **Bachelor of Science in Agriculture**
(Level II Re-Accredited)
Major in: Animal Health

DAYAO SATELLITE COLLEGE

- **Bachelor of Science in Fisheries**
(Level III Re-Accredited)
- **Bachelor of Elementary Education**
(Level III Re-Accredited)
- **Bachelor of Science in Criminology**
(Level II Re-Accredited)
- **Bachelor of Science in Computer Science**
(Level II Re-Accredited)
- **Bachelor of Science in Food Technology**
(PSV)



A BRIEF HISTORY

From humble beginnings, a university grew...

Since its inception in the early 1980s, the modest roots of the institution have become a formidable foundation strengthened through the adept and capable governance of its competent leaders creating positive impact on people. With a fierce commitment to provide quality service to all, Capiz State University, along with its strong and competent task force, maintains a vision with goals leading to a foreseeable future of producing globally-competitive graduates. Today, the university with its nine campuses and satellite colleges, is a landmark as much for its place in the community as its academic programs, research development and extension services, and production continue to grow.

A BRIEF HISTORY

THE PILLARS OF CAPSU

During his time as president, Dr. Botin worked hard to enhance and strengthen the faculty of the growing institution. Championing faculty development, he used to say that it is easier to build buildings than to build people. Perhaps this is due to the fact that he had to weather the odds for the sake of his colleagues. By and large, Botin's pursuit of enhancing the faculty despite the criticisms and difficulties merited him the eternal gratitude of those people whom he had helped.



Dr. Ernesto V. Botin, the first president of the Panay State Polytechnic College

- Excerpts from the article "Dr. Ernesto V. Botin, Visionary Leader; 79" by Genalyn Baranda, *Nuggets*, Vol. 3 No. 1, April 2014



Dr. Rochellir D. Dadivas, the first president of the Capiz State University

It is under Dr. Rochellir D. Dadivas' leadership when Capiz State University achieved many citations and accolades especially in the research development and extension upon the integration of HEIs in the province. Continuing the legacy left by the previous administration, Dr. Dadivas pursued and enhanced existing programs established and gave way to further innovations in the institution.

When Dr. Editha Magallanes was reappointed as president of the Capiz State University in 2012, it only reaffirmed her exemplary leadership that has eventually brought this thriving institution to prominence both in the national and the international stage.

Envisioning CAPSU as the center of academic excellence that renders quality service to the province and its constituents, Magallanes embarked on transforming the institution by prioritizing instruction, research, extension, and production through effective and efficient administration.



Dr. Editha L. Magallanes, the first female president of the Capiz State University.

- Excerpts from the article "FULFILLING THE PROMISE: Making the Mark as SUC President" by Johnny Dariagan, Mark Glenn Villamor and Niño Manaog, *Nuggets*, Vol. 3 No. 1, April 2014

The Capiz State University started with the merger of Mambusao Agricultural and Technical College (MATEC) in Burias, Mambusao and the Capiz Agricultural and Fishery School (CAFS) in Bailan, Pontevedra to become the Panay State Polytechnic College (PSPC) by virtue of Batas Pambansa Blg. 91 signed by President Ferdinand E. Marcos on December 24, 1980.

At the time of the merging of the two schools, MATEC (started June 22, 1958 by virtue of RA 2088, which has two existing satellite campuses located in Tapaz and Sapian) and CAFS (started June 21, 1957 by virtue of RA 1785 and 1786) were headed by Dr. Ernesto V. Botin and Dr. Wenceslao O. Sison Jr., as Superintendents, respectively. The seat of administration of PSPC was in Burias, Mambusao, Capiz.

On August 29, 1981, Dr. Ernesto V. Botin took his oath of office as the first PSPC President and Dr. Wenceslao O. Sison Jr. became his Vice President. With the appointment of Dr. Sison as College President of Northern Iloilo Polytechnic State College, Dr. Anthony N. Navarra was appointed to take over his place as Vice President which was later upgraded to the position of Executive Vice President. Then, the heads of the campuses were called deans.

In 1982, with the approval of the Board of Trustees, the Office of the College President added satellite campuses in the municipalities of Dumarao and Pilar. In 1986, President Corazon C. Aquino reappointed Dr. Botin as PSPC President. When his term ended on July 24, 1993, Dr. Navarra, the Executive Vice President, served as Officer-in-Charge of the College until the appointment of Dr. Rochellir D. Dadivas as the second PSPC President on October 12, 1994.

During the time of Dr. Dadivas, he was assisted by Dr. Anthony N. Navarra, Executive Vice President; Dr. Editha L. Magallanes, Vice President for Academic Affairs; and Dr. Nicolas A. Braña, Sr., Vice President for Research, Development and Extension.

In accordance with the pertinent provisions of Republic Act 7722 (otherwise known as the Higher Education Act of 1994) and Republic Act 8992, on November 4, 1998, the Capiz Institute of Technology (founded 1917) in Roxas City, including its Department of Fisheries in Dayao (formerly Capiz School of Fisheries founded 1961), became an integral part of the PSPC system. This was approved in the 54th Regular Board Meeting held at the CHED Conference Room, San Miguel Avenue, Ortigas Center, Pasig City. However, the official turnover was done on October 25, 1999 by CHED Region VI-Western Visayas Director Tomas P. Parreño to PSPC President Dadivas. Then, on December 19, 2000, Sigma College of Science and Technology (started January 1, 1996 by virtue of RA 7973) in Sigma, Capiz was integrated into PSPC.

A BRIEF HISTORY

In 1999, Cong. Manuel “Mar” A. Roxas of the 1st District of Capiz filed a bill seeking for the conversion of PSPC into a state university. Both the City Council of Roxas City and the Provincial Board of Capiz passed the resolution supporting the bill.

On September 15, 2000, the Board of Trustees approved the new organizational structure of the College with three (3) units, namely: the Roxas City Unit, the Mambusao Unit and the Pontevedra Unit. Each unit was headed by a Chancellor. The Mambusao Unit has six (6) satellite campuses: Burias Campus in Mambusao, Sapian Campus, Tapaz Campus, Sigma Campus, Mambusao Campus, and Dumarao Campus. The Pontevedra

In March 2002 the bill for the conversion of PSPC into a state university was approved in the House of Representatives and the Senate approved the same measure on February 6, 2004. Cong. Rodriguez D. Dadvivas of the 1st Congressional District and Cong. Fredenil H. Castro of the 2nd Congressional District were responsible in lobbying for the passage of the conversion law.

Then, a milestone was reached on March 21, 2004, when President Gloria Macapagal-Arroyo signed into law Republic Act No. 9273 at Capiz Provincial Capitol, Roxas City converting PSPC into a state university, the Capiz State University. At the time of the conversion, the incumbent



A milestone was reached on March 21, 2004, when President Gloria Macapagal-Arroyo signed into law Republic Act No. 9273 at Capiz Provincial Capitol, Roxas City converting PSPC into a state university, the Capiz State University. At the time of the conversion, the incumbent Governor of Capiz was Hon. Vicente B. Bermejo with Hon. Victor A. Tanco as Vice Governor. Following the provision of the University Charter, the seat of administration was transferred to Roxas City.

Unit has Pontevedra Campus and Pilar Campus; while the Roxas City Unit has Roxas City Campus and Dayao Campus. The first Chancellors were Dr. Nenita A. Beluso for Pontevedra Unit, Supt. Primitivo V. Bangcoyo for Roxas City Unit and Dr. Geronimo L. Gregorio for Mambusao Unit. The campuses were headed by Campus Administrators who report directly to the Chancellors.

In 2001, the seat of administration was transferred to Mambusao Campus for accessibility and ease of communication. The second sets of Chancellors were Dr. Edgar M. Dilla for Pontevedra Unit, Dr. Genoveva N. Labaniego for Mambusao Unit and Dr. Evaristo M. Magoncia for Roxas City Unit. With the retirement of Dr. Navarra in 2003, the position of Executive Vice President, being co-terminus, ceased to exist.

Governor of Capiz was Hon. Vicente B. Bermejo with Hon. Victor A. Tanco as Vice Governor. Following the provision of the University Charter, the seat of administration was transferred to Roxas City.

Dr. Rochellir D. Dadvivas, the incumbent PSPC President at the time of conversion became the first University President. The three Vice Presidents were Dr. Editha L. Magallanes, Vice President for Administration and Finance; Dr. Aladino L. Leccio, Vice President for Academic Affairs; and Dr. Geronimo L. Gregorio, Vice President for Research and Extension.

On July 7, 2008, after the retirement of Dr. Dadvivas as University President, Dr. Editha L. Magallanes was appointed as the second University President of Capiz State University. During the term of Dr. Magallanes, her

A BRIEF HISTORY

CONTINUING THE LEGACY



Dr. Editha C. Alfón, the current University President of Capiz State University

Dr. Editha C. Alfón, who after having been installed into office as University President of Capiz State University on September 8, 2016, further exemplifies her true dedication to quality service to the university with integrity, transparency, and accountability.

Dr. Alfón who rose from being a faculty member, a Registrar, a Campus Administrator, a Vice President for Academic Affairs, and now a University President, truly and completely prepared her to be one- a true and experienced leader. A very simple lady who intentionally looks at the person's capacity to lead, and willingly trains anyone who desires to be one.

Her consistent exemplary performance and firm leadership style coupled with calm demeanor, catapulted her into a second term as University President of Capiz State University. She was re-appointed into office by the governing Board by virtue of Board Resolution No. 003, series of 2020 for a term of four (4) years commencing on September 8, 2020.

In Dr. Alfón's second term, the University is journeying ahead with courage and determination in achieving its vision of becoming "A highly globalized University towards a just and equitable society" by sustaining excellence in its various degree programs and improving the delivery of its services.

Vice Presidents were Dr. Aladino L. Leccio for Administration and Finance, Dr. Herminia B. Gomez for Academic Affairs and Dr. Geronimo L. Gregorio for Research, Development and Extension (RDE). Per Board of Regents' Resolution No. 1112, series of 2009, the chancellor positions were abolished in view of overlapping functions with the campus administrators.

Having been rated Outstanding by the Evaluation and Search Committee towards the end of her first term as University President in June 2012, Dr. Editha L. Magallanes was re-appointed as President of Capiz State University on July 7, 2012.

With the retirement of Dr. Gregorio, Dr. Cora F. Navarra replaced him as Vice President for Research, Development and Extension effective November 7, 2012. The untimely death of Dr. Cora F. Navarra, left the VP RDE office vacant. Dr. Pedro G. Gavino was then designated as the Officer-in-Charge on March 5, 2014 and assumed office on June 1 of the same year.

With the retirement of Dr. Herminia B. Gomez in September 17, 2014, Dr. Editha C. Alfón was designated as the Vice-President for Academic Affairs until September 7, 2016. And now, she serves as the University President after the retirement of Dr. Editha L. Magallanes.

Dr. Alfón holds the university presidency effective September 8, 2016 to date by virtue of Resolution No. 50, series of 2016. The three vice presidents of the new administration are Dr. Nilo D. Delfin as the VP for Administration and Finance, Dr. Susan O. Dangan as the VP for Academic Affairs, and Dr. Lucy A. Beluso as the VP for Research Development and Extension.

By virtue of BOR Resolution No 117, series of 2017, the post for Vice President for External Affairs and Linkages was created. Dr. Mary Ann B. Martelino was designated as the first Vice President for External Affairs and Linkages.

With Dr. Alfón's dedicated service, participative leadership style, and transparent governance, she was re-appointed by the Board for a term of four (4) years as University President on September 8, 2020 by virtue of Board Resolution No. 003, series of 2020. The four (4) designated Vice Presidents under her second term are Dr. Wennie F. Legario as Vice President for Administration and Finance, Dr. Susan O. Dangan as Vice President for Academic Affairs, Dr. Efren L. Linan as Vice President for Research Development and Extension, and Dr. Mary Ann B. Martelino as Vice President for External Affairs and Linkages.



The early structures of the institution situated at the Pontevedra Campus, known then as the Capiz Agricultural and Fishery School (CAFS), circa 1960s.



EXECUTIVE
SUMMARY

EXECUTIVE SUMMARY

Capiz State University has taken a leap amidst the challenges posed by the COVID-19 outbreak. The University has now achieved considerable progress amidst the stagnating impact of the pandemic. The year 2022 has opened opportunities to surpass these challenges and attain new heights while staying true to our mandate of providing quality, transformative education. This is made possible by fostering a supportive and inclusive community that values diversity and encourages creativity and critical thinking.

The University is able to sustain the number of enrollees for the year 2022, considering implementation of the free tuition and the online/blended learning modalities. Since the onset of the COVID-19 pandemic, the University has since seen a huge spike in the number of enrolled students, given the free tuition and the quality of instruction offered despite the online mode of instruction.

In its quest to provide quality graduates, Capiz State University continues to offer quality instruction with the aim of contributing to the nation's socio-economic development. For AY 2021-22, the University was able to produce 3,866 graduates. Of these graduates, 476 were cum laude, 44 were magna cum laude, and 1 was cum laude.

Looking into the University's performance in the different professional licensure examinations administered by the Professional Regulation Commission, 43 % or 437 out of 1,005 takers passed in 2022. The University was able to produce 4 topnotchers, 1 for the Social Worker Licensure Examination, and 3 for the Registered Master Electrician Licensure Examination.

The University has a 65 percent employability of its graduates based on the results of the employability tracer study conducted by the different campuses and satellite colleges.

As a sign of the University's quest in the delivery of quality service, various graduate and undergraduate programs were submitted for accreditation. For the year 2022, 56 undergraduate and 23 graduate programs have passed the different levels of accreditation conducted by the Accrediting Agencies for Chartered Colleges and University of the Philippines (AACUP).

Likewise, the Commission on Higher Education has issued the certificate of program compliance to 43 undergraduate and 6 graduate programs of the University. Six programs in the undergraduate level have thus renewed their COPC.

The Office of the Student Affairs and Services continued to deliver effective support in ensuring academic and holistic success of our learners. With this, 100% of the students availed free higher education. Furthermore, 1,991 students availed the Tertiary Education Subsidy (TES),

while 642 of students availed the Tulong Dunong Grants. Also, 493 of students availed private and other government scholarships and grants. The office also saw 95% increase in student access on Student Welfare and Development Activities, such as psychosocial support, medical and dental services, participation to local, national, and international conferences, among others.

Recognizing the significance of linkages and partnerships locally and internationally, the office has never ceased to create partnerships towards potential partners. The Office of the Vice President for External Affairs and Linkages has sealed partnerships in different local and international agencies in 2022. To wit, they are as follows:

- Institute of Integrated Electrical Engineers of the Philippines, Incorporated- Kuwait Chapter- January 28, 2022
- United Architects of the Philippines – Qatar Chapter- February 23, 2022
- Philippine Society of Mechanical Engineers- Qatar Chapter- February 23, 2022
- National Master Plumbers Association of the Philippines- Qatar Chapter – February 23, 2022
- Luna Academy, Inc- January 23, 2023
- National Master Plumbers Association Of The Philippines (NAMPA) Qatar Chapter
- Philippine Society Of Mechanical Engineers (PSME) Qatar Chapter
- United Architects Of The Philippines (UAP) Qatar Chapter
- Japan Hospitality Learning Center (JHLCA)
- Universitas Muhammadiyah Kotabumi, Indonesia (UMKO)
- Pangkep State Polytechnic Of Agriculture (POLIPANGKEP), Indonesia
- International Cultural Communication Center Malaysia (ICCCM)
- Go Study Global Education Groups (Prc) Co., Limited, China (Go Study)

Capiz State University also joined the University Consortium of the Southeast Asian Regional Center for Graduate Study and Research in Agriculture (SEARCA) funded by the Commission on Higher Education (CHED) project Leveling Up Philippine Higher Education Institutions in Agriculture, Fisheries, and Natural Resources (LevelUPHEI AFAR). With this, 5 faculty members from the College of Agriculture qualified for the program and they were hosted by Institut Pertanian Bogor (IPB) in Bogor, Indonesia.

As a research university, CAPSU strives to nurture a culture of innovation among its faculty members and staff. In line with this, the Research, Development, and Extension Office had crafted its three-year agenda and five-year roadmap last April 20, 2022, which aimed to boost the internationalization of research engagements, and commercialization of the outputs of the faculty researchers. With the implementation of the researches, a ceremonial signing of the research agreement among the

faculty was conducted. The RDE office had also conducted its first quarter meeting held at the various campuses to assess the accomplishments of the campus/college accomplishments in terms of research and extension.

Through partner agencies, the Research Office continuously monitors and supervises the 12 externally funded research programs and projects funded by DA-BAR, DA-RO6, DOST-PCAARRD, CHED-IAS, USDA, and other partner agencies.

In terms of patent filing three technologies were filed as patent, two for Utility Model, and among the 45 technologies applied for copyright, 35 were registered while 10 were still in the process of an application.

The Intellectual Property Management Office, through its DOST-PCAARRD-CAPUSU ATBI Project, had catered to the learning visits and benchmarking activities of some SUCs in the region to look into the best practices, policies, and strategies. Among the SUCs visited the project are the TUPV, CPSU, ASU, UPV, and Hublag Foundation. Moreover, CAPUSU, through the RDE IPMO had been recognized by the IPOPHIL as the Top Utility Registrant from 2017 to 2021 and Second Place - Top ITSO Filer from 2016 to 2021 on June 6, 2022, as part of its 25th Anniversary Celebration.

The Research Development and Extension Office also conducted its annual PAGTUKIB expo which focuses on the various food and beverages products from the different campuses, satellite colleges, and incubatees from the Agri-Aqua Technology Business Incubator (ATBI) and Agribusiness Incubator (ABI) of Capiz State University. Trade shows, cooking competitions, and technology pitching were the highlights of the event.

A Utilization forum was done for the Riverine Improvement towards a Sustainable Ecotourism in Roxas City, Capiz, Philippines (RISE Capiz) Project. The forum was attended by the beneficiaries of the project, namely: the palina and Cadimahan River Tour Operators.

All in all, the University faculty-researchers have produced a total of 75 researches for the year 2022, a significant spike from the slump brought about by the pandemic. This only indicates that the University is once again on track to its commitment of producing quality research and nurturing an environment that breeds inquisitive minds and development-oriented learners.

On-going Funded Projects

1. R.I.S.E. Capiz (Riverine Improvement for Sustainable Ecotourism in Roxas City, Capiz)
2. Enhancing the Agri-Aqua Food Value Chain through Smart Technologies and Partnerships towards Food Resiliency in the New Normal

3. RD Lead Program
4. Establishment of DA-BAR CAPUSU Agribusiness Incubator
5. Development of Pineapple Stripping Machine
6. CAPUSU Agri-Aqua Technology Business Incubator (Phase 2)
7. From Substrates to Utilization: Ensuring Vermicompost Quality and Safety

Newly funded projects

- Adoption of Mangrove Crab Hatchery Seed Production and Nursery Facility in Pilar, Capiz
- Province-led Agriculture and Extension System (PAFES)
- Plant Nursery
- Coffee Demo Farm
- Regional Agri Aqua Innovation Enhancement (RAISE) Program in Western Visayas
- Project 1. Regional Intellectual Property and Technology Management (IP-TBM)
- Project 1A. Enhancing Technology Transfer through RAISE in Capiz State University
- Project 3. Regional Agri-Aqua Technology Incubator (ATBI)
- Project 3A. DOST PCAARRD-CAPUSU Agri-Aqua Technology Business incubator (ATBI)
- Innovations Laboratory for Process Machinery and Related Technology Development (i-Lab ProMaTech)
- Expanding the Operation of the DA-BAR TBI Program of CAPUSU (Phase 2)
- Sustainably Acceleration and Fostering Equitable Fishery Market Engagement in Pilar Bay, Capiz (SAFE Project) - Partnership with SIKAT (Sentro para sa Ikauunlad ng Katutubong Agham at Technolohiya), Inc.
- Establish a Qualisafe Lab thru Upgrading of Microbiology Laboratory at CAPUSU Dayao Campus and Physico-Chemical Laboratory at Mambusao Campus
- Enhancement, Pilot Testing and Market Study of Biomass-Fried Dryer
- Project 1. Regional Intellectual Property and Technology Management (IP-TBM)
- Project 1A. Enhancing Technology Transfer through RAISE in Capiz State University
- Project 3. Regional Agri-Aqua Technology Incubator (ATBI)
- Project 3A. DOST PCAARRD-CAPUSU Agri-Aqua Technology Business incubator (ATBI)6.

Since the onset of the community quarantine, the University's Community Extension Services Office (CESO) a total of 355 Projects, Programs, and Activities (PPAs) were conducted and initiated by different campuses and satellite colleges, benefitting a total of 15, 491 individuals comprised of recipients from the university, community, and other partner

EXECUTIVE SUMMARY

agencies as well, across the region. The participants and beneficiaries were given technical information and tangible assistance, which helped them reconsider opportunities and recover from the pandemic's current situation. Nevertheless, CAPSU faculty extension implementers have paved the way in continuously helping uplift the life of the community members.

The year 2022 has been a busy year for the Office of the Vice President for Administration and Finance. A number of infrastructure projects have been implemented, all intended to modernize Capiz State University and ensure that the campuses and satellite colleges become pandemic-resilient and future-proof learning hubs. So far, the University has 18 completed projects, including the expansion of the Central Administration building.

The faculty members and staff continued their pursuit towards professional growth and development. Faculty members participated in a total of 1,589 local, regional, national, and international seminars, trainings, conferences, and other forms of professional development programs, benefitting a total of 1,391 attendees across the nine campuses and satellite colleges of the University.

The Administration, likewise, continues to advocate for a gender sensitive and responsive University where diversity is celebrated and taken as an asset. Hence, the Office of Gender and Development has laid a robust program of activities throughout 2022 aimed at empowering every CAPSUnian regardless of gender, race, religion or any affiliation.

The University's income generation projects have seen a stark increase in Fiscal Year 2022 compared to Fiscal Year 2021. In particular, net income rose 98%, a sign that the University's IGP initiatives have recovered amidst losses sustained during the pandemic.

The biggest gainer among the IGP commodities was the Fish Pond, which saw net income rise to 286% from P306,360.05 in 2021 to P1,182,170.64 in 2022, followed by coconut production, with net income jumping from P49,744.82 in 2021 to P83,425.00 in 2022. Travel and Tours, with zero income in 2021 has earned 155,303.62 in 2022.

The year 2022 is a recovery year for CAPSU. The University is looking forward to resume its full swing in maximizing its potentials in delivering quality education through instruction, research, extension, production, and governance.

EDITHA C. ALFON, PhD
SUC President III

Quality University instruction is a strong foundation in nation-building. As such, Capiz State University endeavors to provide quality instruction to ensure that students acquire the knowledge and skills they need to succeed in their chosen careers. High-quality instruction helps students develop critical thinking, problem-solving, and analytical skills, engaging them in enriching and life-changing learning experiences with the help of knowledgeable, passionate, and dedicated members of the faculty. Integrating the four-four functions, the University's instructional initiatives foster research and innovation to produce quality graduates who would play active roles in nation-building.

STRONG FOUNDATION



ENROLMENT



The University is able to sustain the number of enrollees for the year 2022, considering implementation of the free tuition and the online/blended learning modalities. Since the onset of the COVID-19 pandemic, the University has since seen a huge spike in the number of enrolled students, given the free tuition and the quality of instruction offered despite the online mode of instruction.

SUMMARY OF ENROLMENT

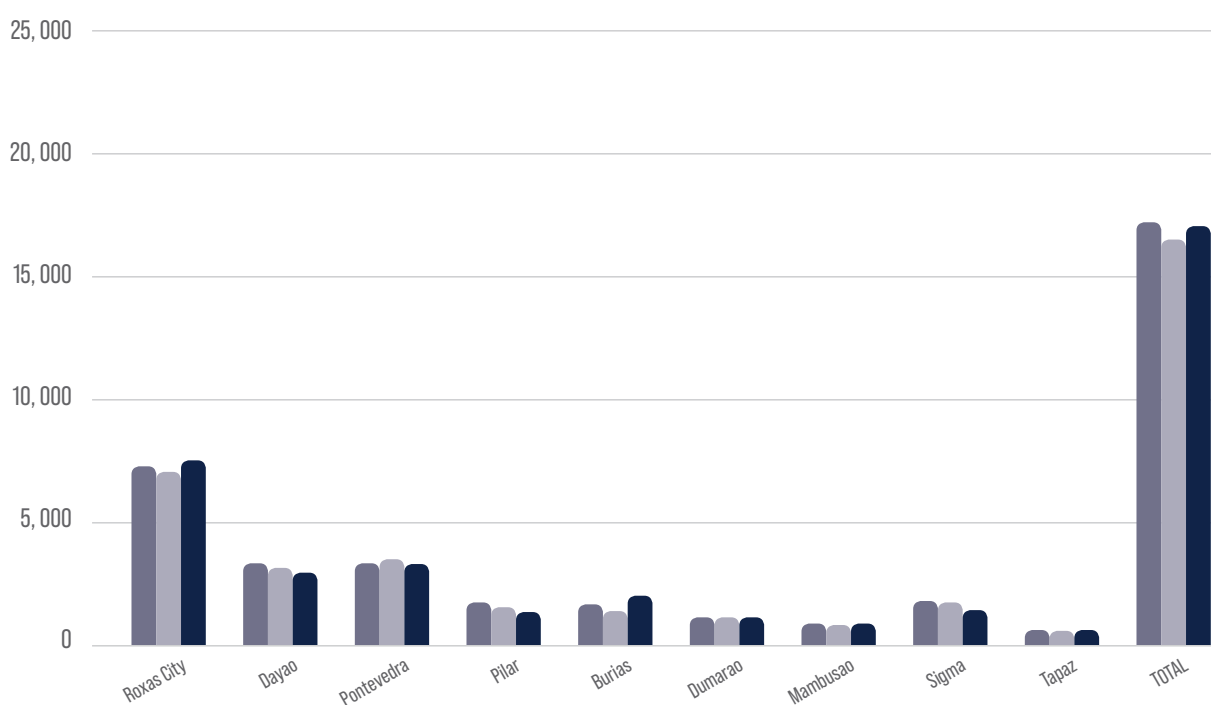

1st SEM 2021-2022	7,446	3,874	3,884	1,515	1,589	1,159	945	2,353	723	23,394
2nd SEM 2021-2022	7,141	3,610	3,966	1,456	1,549	1,107	911	2,234	660	22,364
1st SEM 2022-2023	7,726	3,502	3,784	1,435	1,721	1,217	1,047	1,947	725	23,104

GRADUATES

In its quest to provide quality graduates, Capiz State University continues to offer quality instruction with the aim of contributing to the nation's socio-economic development. For AY 2021-22, the University was able to produce 3,866 graduates. Of these graduates, 476 were cum laude, 44 were magna cum laude, and 1 was cum laude.

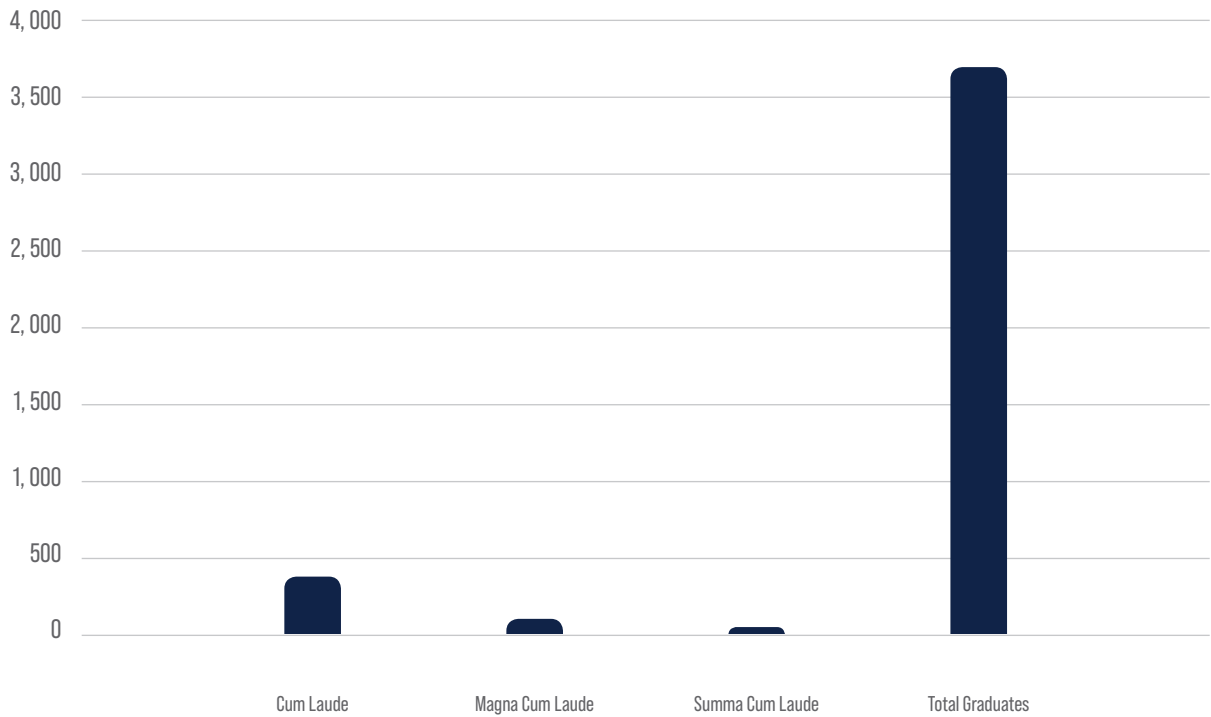

BOARD PERFORMANCE

A total of 1,005 takers took different licensure examinations organized by the Professional Regulation Commission (PRC) for 2022. Of this, 43% or 437 were able to pass. The University was able to produce 4 topnotches, 1 for the Social Worker Licensure Examination, and 3 for the Registered Master Electrician Licensure Examination.

PROGRAM NAME	EXAM DATE (MM/DD/YYYY)	NO. OF TAKERS (1ST TIME)	NO. OF PASSERS (1ST TIME)
Roxas City Main Campus, Fuentes Drive, Roxas City			
BS Architecture	1/21-23/2022	6	3
BS Mechanical Engineers	2/27-28/2022	3	2
BS Electrical Engineers	4/26-27/2022	18	12
BS Civil Engineers	5/1-2/2022	19	6
BS Architecture	6/17 & 19/2022	21	16
BS Mechanical Engineers	8/13-14/2022	14	8
BS Electrical Engineers	9/3-4/2022	13	2
Licensure Professional Teachers	10/02/22	161	117
BS Civil Engineers	11/19-20/2022	65	27
Dayao Satellite College, Dayao Roxas City			
BS Criminology	6/12-14/2022	64	18
Licensure Professional Teachers	10/02/22	10	8
BS Fisheries	10/6-7/2022	6	2
BS Criminology	12/4-6/2022	285	82
Pontevedra Campus, Bailan, Pontevedra, Capiz			
BS Agricultural and Biosystem Engineer	9/15-16/2022	15	4
Licensure Professional Teachers	10/02/22	16	9
BS Agriculture	11/22-24/2022	35	11
Pilar Satellite College, Natividad, Pilar Capiz			
BS Social Work	2/22-23/2022	2	2
BS Social Work	9/19-21/2022	16	8
Licensure Professional Teachers	10/02/22	31	25
BS Agriculture	11/22-24/2022	6	1
Burias Campus, Burias, Mambusao Capiz			
BS Agricultural and Biosystem Engineer	9/15-16/2022	19	4
Licensure Professional Teachers	03/27/22	1	1
Licensure Professional Teachers	10/02/22	14	10
BS Agriculture	11/22-24/2022	17	6
Mambusao Satellite College, Poblacion Mambusao Capiz			
Licensure Professional Teachers	10/02/22	11	7

BOARD PERFORMANCE

Sigma Satellite College, Poblacion Sur, Sigma Capiz			
Licensure Professional Teachers	03/27/22	1	1
Licensure Professional Teachers	10/02/22	5	4
Dumarao Satellite College, Condingle, Dumarao Capiz			
Licensure Professional Teachers	10/02/22	5	3
BS Agriculture	11/22-24/2022	29	4
BS Criminology	12/4-6/2022	54	12
Tapaz Satellite College, San Julian, Tapaz Capiz			
Licensure Professional Teachers	10/02/22	38	20
BS Agriculture	11/22-24/2022	5	2
TOTAL		1,005	437
PERCENTAGE			43%



 Republic of the Philippines
CAPIZ STATE UNIVERSITY
 Pilar Satellite College

Congratulations

PONSARAN, LENERY B.

Top 9 (82.20%)

February 2022
Social Worker Licensure Examination

PROUD OF YOU!
FAMILIAR FAMILY

Congratulations!

September 2022 Registered Master Electrician (RME)
 Board Examination Passers

Top 1 (95%) Top 3 (94%) Top 7 (92%)



Kin
AMATA



Christian
HUENDA



Henry Mar
BEBITA

63.18% National Passing Percentage
72.73% CapSU Passing Percentage

Your CapSU Family is proud of you!

EMPLOYABILITY

The University has a 65 percent employability of its graduates based on the results of the employability tracer study conducted by the different campuses and satellite colleges.

65%
EMPLOYABILITY

Total Graduates (2020)	E	UE	NT
1,026	664	291	71

CURRICULUM DEVELOPMENT

The University will be offering the following new courses which have already been endorsed for Board Approval: BSEd Social Studies (CAPSU Tapaz); Master in Business Administration (Pontevedra); BS Accountancy (Enhanced) (Roxas City Main Campus); and BS Fisheries (Enhanced) (CAPSU Dayao).

QUALITY ASSURANCE AND ACCREDITATION

Accreditation Status

As a sign of the University's quest in the delivery of quality service, various graduate and undergraduate programs were submitted for accreditation. For the year 2022, the a total of 56 undergraduate and 23 graduate programs have passed the different levels of accreditation conducted by the Accrediting Agencies for Chartered Colleges and University of the Philippines (AACUP)

	Accredited Undergraduate Programs	Accredited Graduate Programs
Preliminary Survey Visit	9	0
Candidate	0	2
Level I	3	2
Level II	20	15
Level III	24	4
Total	56	23

COPC

In terms of the Certificate of Program Compliance, the Commission on Higher Education has issued COPCs to 43 undergraduate and 6 graduate programs of the University. Six programs in the undergraduate level have thus far been issued with a renewed COPC.

	Number
No. of Undergraduate programs with COPC	43
No. of Graduate programs with COPC	6
No. of Undergraduate Programs with COPC Renewal	6

STUDENT AFFAIRS AND SERVICES

This Student Affairs and Services Annual Report is an important opportunity to reflect on a year of adaptive innovations that ensured Student Affairs' continued effectiveness in supporting every student's success despite our unprecedented environment and the challenges of remote work and learning. The following are the accomplishments of the Office of the Student Affairs for the year 2022:

- 100% of the students availed the Free Higher Education.
- 1,991 students availed the Tertiary Education Subsidy (TES).
- 642 of students availed the Tulong Dunong Grants
- 493 of students availed Private and other government scholarship and grants
- 95% increase in student access on Student Welfare and Development Activities.
- 98% increase of Availment of psychosocial support.
- 100% of the new, ongoing, shifter and transfer students reported feeling connected to the University after the Face to Face and Online Orientation.
- 80% increase in participation of parent and guardian attendance on orientation.
- 139 of the student organizations applied are accredited
- 100% of the student population availed the Medical and Dental Services
- The institution catered various services to the 23,146 official enrolled students.
- 75% increase of student participation in various activities both local, national and international.
- Student International Mobilization on online learning modalities.
- Student Services delivered through the implementation of the SAS Continuity Plan Strategies
- 100% of the Student organizations conducted their approved action plan activities
- 100% of the SAS clientele rated the office Excellent in delivering quality service.

The University's Office of Socio-Cultural Services continues provide enriching experiences to CAPSUnians by organizing various cultural and artistic activities. The year 2022 was a busy year with side-by-side activities and programs that showcased the world-class CAPSUnian talents.

ENRICHING EXPERIENCES



SOCIO-CULTURAL SERVICES

CHED REGION 6 – 55TH ASEAN FOUNDATION ANNIVERSARY (ASEAN EXHIBITION)

SEPTEMBER 26, 2022

CapSU Main Chorale performed at the 55th Founding Anniversary of the Association of Southeast Asian Nation, this university, in cooperation with the Higher Education Institution in Panay and Guimaras Island ASEAN EXHIBITS held at Robinson's Place Jaro, Iloilo City on September 26-30, 2022.



PTCAO, PFDS-CAPIZ COMPLETE SIX-BATCH SAOT CAPIZ FOLK DANCE TRAINING WORKSHOP UNDER CILT

NOVEMBER 19 – DECEMBER 4, 2022

Eighty-seven-participant Saot Capiz: Capisnon Folk Dance Training Workshop conducted at the Capiz State University Main Campus (Roxas City) on December 4, 2022 with participants coming from Roxas City and the municipalities of Panay and Ivisan, capped off the six-part aforementioned training-workshop implemented under the Capiz Institute of Living Traditions – led by the Provincial Government of Capiz through the Provincial Tourism and Cultural Affairs Office (PTCAO) in partnership with the National Commission for Culture and the Arts (NCCA).



Staged on six (6) separate venues with over 300 participants composed of students, teachers and dance directors coming from fifteen (15) municipalities and Roxas City, the trainings were led by the Philippine Folk Dance Society – Saot Capiz Chapter. At the helm, were Marcelo JC Diaz, Mary Gene Panes, Polansky Pinky Barrientos, Lemuel Pastrana and Romely Alcorano who served as trainers of the Capisnon folk dances Mamalagkaw, Pahid, Sulognon, Cabatingan and Saad. The first training-workshop that kicked off on November 19, 2022 conducted particularly for the students and teachers of Cuartero was also joined by cultural masters Socorro Basamod, Noemi Esmael, and Suprema Fabiaña who co-trained for the Sayaw kay San Antonio.



The Saot Capiz Folk Dance Training Workshop is one of the component activities implemented under the Capiz Institute of Living Traditions that pursues to enhance, train or capacitate participants in particular skills that would help protect, sustain, research, document, promote, and develop the living traditions of the province.



SOCIO-CULTURAL SERVICES

UNIVERSITY MEET 2023

JANUARY 3-6, 2023

Capiz State University held its first in-person Culture and Arts Festival since the onset of the COVID-19 pandemic. Embodying and upholding the theme, "Embracing Sports, Culture and the Arts Beyond the New Normal", the University Meet was held last January 3-6, 2023 at the Capiz State University - Main Campus, with Tapaz Satellite College as the host.



SULHAY: A CULTURAL SHOW
Capiztahan Festival 2022

APRIL 22-23, 2022

The CAPSU Main Chorale and CAPSU Main Dance Troupe were featured at Sulhay, a Cultural Performance organized during the Capiztahan Festival 2022 in partnership with the Capiz Provincial Tourism and Cultural Affairs Office.



The poster features a central graphic with the word "Sulhay" in a large, red, cursive font. Above it, the "Capiztahan 2022" logo is displayed with colorful bunting. Below the title, the text "A CULTURAL PERFORMANCE" is written in a bold, sans-serif font. The word "featuring" is in a smaller, italicized font. The featured groups are listed in green: "CAPIZ STATE UNIVERSITY MAIN CHORALE", "CAPIZ STATE UNIVERSITY DANCE TROUPE", "FILAMER CHRISTIAN UNIVERSITY CHORALE", and "FILAMER CHRISTIAN UNIVERSITY SILAK DANCE COMPANY". The musicians are listed in black: "ARNEL HEREMIAS (VIOLINIST)", "ANDREW UPANO (GUITARIST)", and "GLENN ESICO (SAXOPHONIST)". The date and time are "APRIL 22-23, 2022 6:30 PM" and the location is "CAPIZ PROVINCIAL PARK, ROXAS CITY, CAPIZ". At the bottom, a red banner contains the text: "FOR THOSE WHO ARE WILLING TO EXTEND THEIR HELP TO THE VICTIMS OF TD AGATON, WE WILL SET UP A RECEIVING AREA FOR YOUR IN-KIND DONATIONS". The background includes stylized illustrations of people in traditional attire and decorative wave patterns in green, red, and white.

Sulhay
A CULTURAL PERFORMANCE

featuring

CAPIZ STATE UNIVERSITY MAIN CHORALE
CAPIZ STATE UNIVERSITY DANCE TROUPE
FILAMER CHRISTIAN UNIVERSITY CHORALE
FILAMER CHRISTIAN UNIVERSITY SILAK DANCE COMPANY

ARNEL HEREMIAS (VIOLINIST)
ANDREW UPANO (GUITARIST)
GLENN ESICO (SAXOPHONIST)

APRIL 22-23, 2022 6:30 PM
CAPIZ PROVINCIAL PARK, ROXAS CITY, CAPIZ

FOR THOSE WHO ARE WILLING TO EXTEND THEIR HELP TO THE VICTIMS OF TD AGATON, WE WILL SET UP A RECEIVING AREA FOR YOUR IN-KIND DONATIONS



SOCIO-CULTURAL SERVICES

18TH FIESTAS IN THE CITY (CAPIZ DAY) – DUNOG CAPISON: A CULTURAL PERFORMANCES

APRIL 22, 2022

CapSU Main Chorale joined the Province of Capiz in celebrating the 18th Edition of Fiestas in the City with the themed: "Celebrating Heritage and Tradition," Fiestas in the City aims to showcase in one place the celebrations of the provinces of Aklan, Antique, Capiz, Guimaras, Iloilo, and Negros Occidental, and the highly-urbanized cities of Bacolod and Iloilo.



It could never be denied that providing a holistic learning environment is crucial in creating a well-rounded individual. At Capiz State University, the Office of University Sports Services facilitate the offering of different sports and athletic activities aimed at enhancing students' skills and talents through active participation in different competitions and provide opportunities for high level of skill development and competitive success.

ENHANCING SKILLS & TALENTS



SPORTS SERVICES

Date	Activity
January 2022	<ul style="list-style-type: none"> ■ Prepared and submitted program of Receipt and Expenditures for FY 2022 ■ Prepared and submitted Annual Procurement Plan
May 2022	<ul style="list-style-type: none"> ■ Conducted meeting on the CHED guidelines on the implementation of return to collegiate athlete competitions during the Covid-19 Pandemic ■ Participated on 1st CHED Regional online chess tournament. CAPSU garnered the 10th place of the overall championship ■ Submitted to CHED Central Office Proposal on community sport and wellness grant
July 2022	<ul style="list-style-type: none"> ■ Conducted meeting on the CHED guideline on Tertiary Sports Development Program (TSDP)
October 2022	<ul style="list-style-type: none"> ■ Conducted joint meeting of sports and cultural activities on the preparation for the University Sportsfest and Conference ■ Attended ESports zoom platform school wide webinar
December 2022	<ul style="list-style-type: none"> ■ Conducted meeting on the finalization of activities for the University Sportsfest and conference

The University Libraries have been actively supporting the institution's academic programs by providing quality print and electronic resources and ubiquitous services to cater the learning needs of the students both in-person and online. Among the recent innovations implemented included the operation of online public access catalogs, provisions for online databases, and virtual reference assistants, on top of continuous acquisition of print reference materials and availability of information service.

QUALITY INFORMATION



LIBRARY SERVICES

TITLE OF THE CHART

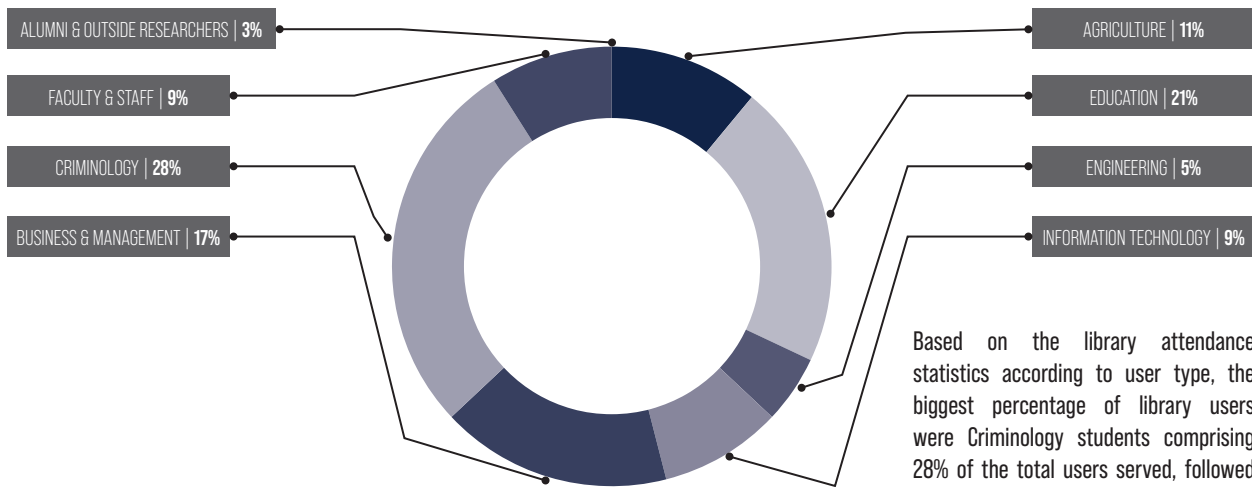
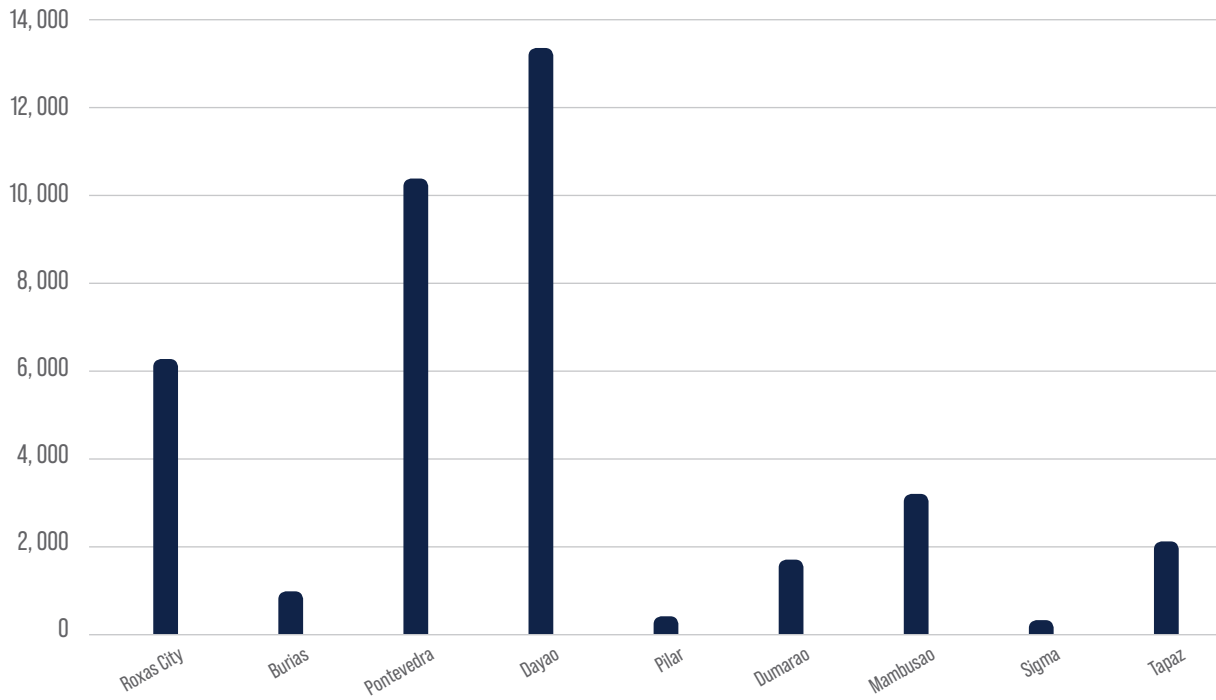

Based on the library attendance statistics according to user type, the biggest percentage of library users were Criminology students comprising 28% of the total users served, followed by Education students (21%), and from Business and Management group (17%).

LIBRARY MATERIALS UTILIZATION STATISTICS

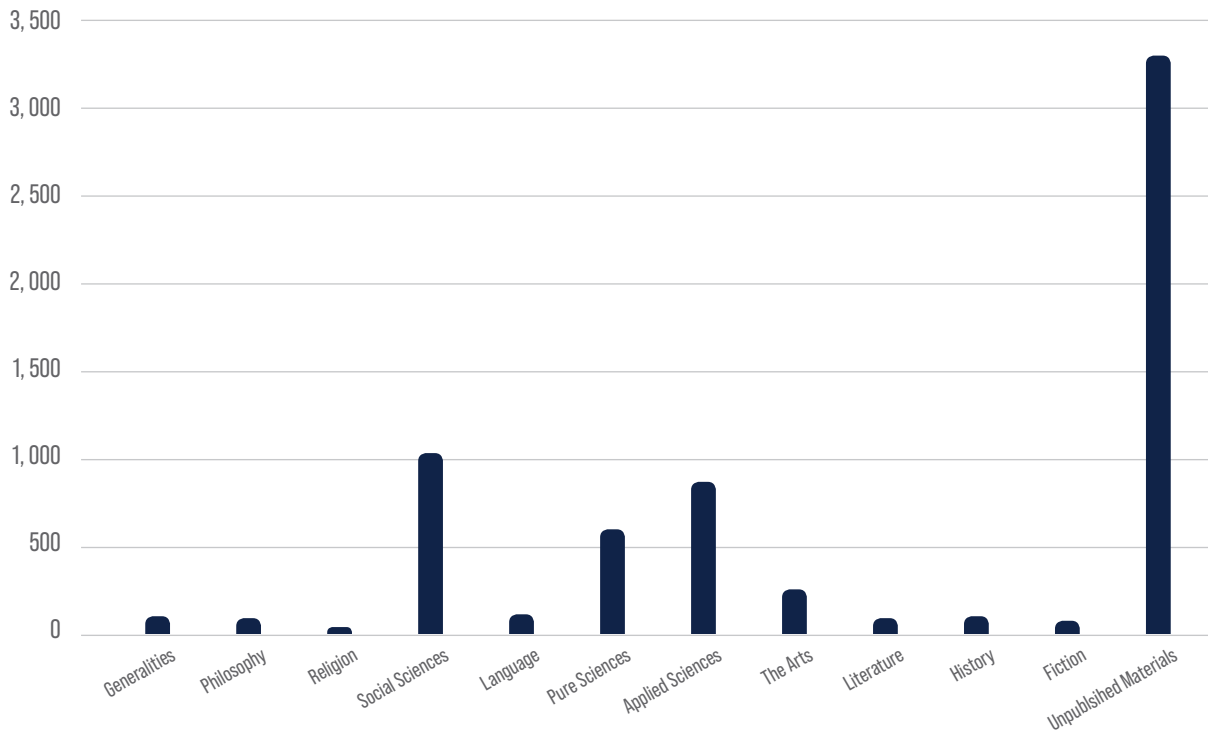

As to library materials utilization, Unpublished Materials posted the highest number of usage (3,335). The most number of books used were from the Social Science classification (1,067) while the least were Religion books (35).

LIBRARY SERVICES

PURCHASED BOOKS BY CAMPUS ACCORDING TO NUMBER OF TITLES AND COPIES

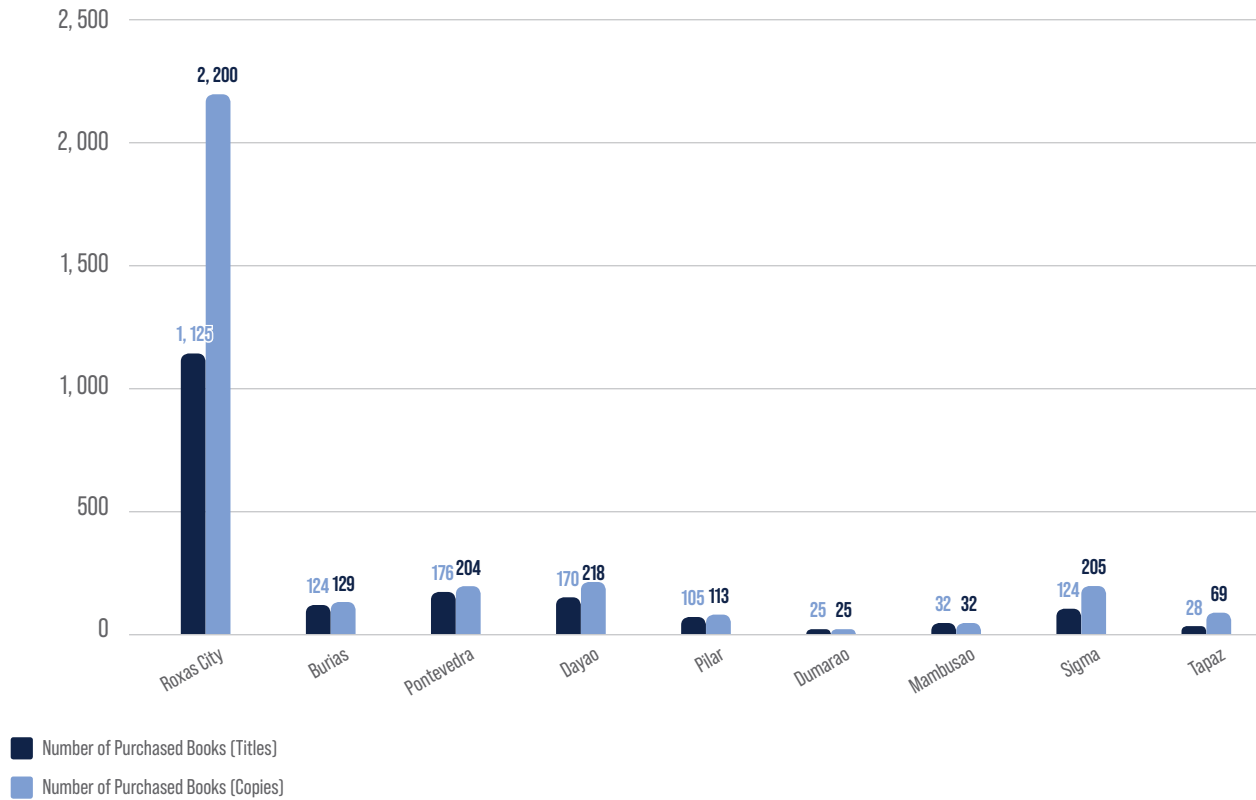

For CY 2022, the total number of books purchased by the university was 1909 titles and 3,195 copies. Of the nine campuses, Roxas City procured the most number (2,200 copies) while Dumarao has the least (25 copies).

BOOK PURCHASE AND SUBSCRIPTION EXPENSES

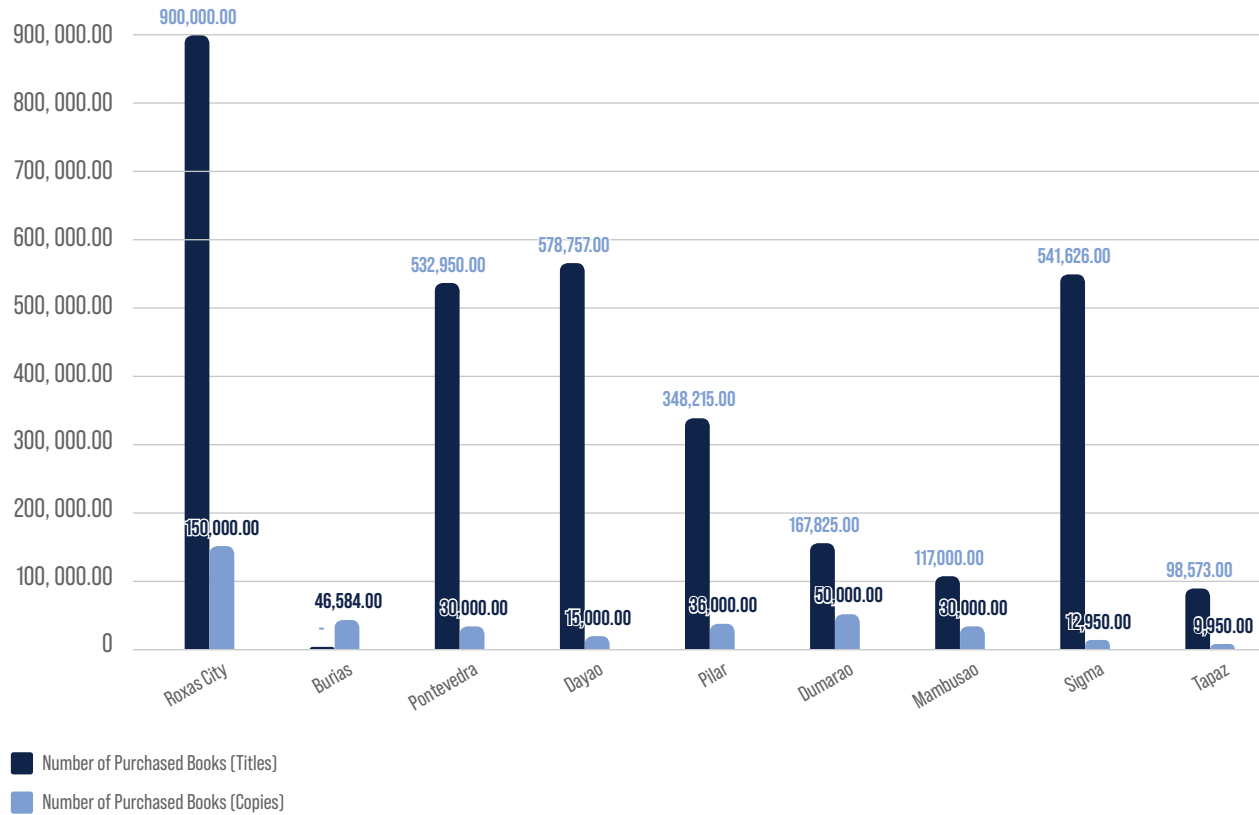

All campuses spent Php3,284,946.00 for the purchase of books and Php380,484.00 for the subscription of periodicals.

LIBRARY SERVICES

LIBRARY DEVELOPMENTS

1. Construction of three-storey multiuse building (Roxas City)
2. Minor repairs on floor and roof (Roxas City)
3. Construction of Library Covered Pathwalk/Canopy (Burias and Dayao)
4. Repair of Library Ceiling, Bookshelves, Lights, Electrical wires and socket (Burias)
5. Cleaning and Maintenance of all air conditioning units (Pontevedra, Sigma and Dayao)
6. Purchase of construction materials for the repair of canopy and ceiling (Pontevedra)
7. Conduct of termite and other pest control/treatment (Roxas City, Pontevedra, and Burias)
8. Repair of library roofing, ceiling (Pilar and Dumarao)
9. Installation of electricals (Dumarao and Pilar)
10. Repainting of library (Pilar and Tapaz)
11. Construction of Library Lounge Area (Poblacion)
12. Repair of CR door (Sigma)
13. Installation of steel grills at the entrance door of the Library Building (Tapaz)
14. Installation of solar power at the library (Tapaz)
15. Acquisition of computer units, web camera and headset from CHED-IDIG Grant (20 units each for big campuses and 15 units each for satellite colleges)
16. Acquisition of laptops and other ICT facilities
17. Procurement of furniture (study carrels, shelves, chairs, steel cabinets, computer tables, periodical racks)
18. Upgrading of internet bandwidth
19. Installation of internet connection
20. Procurement of appliances and other facilities (photocopying machine, barcode scanners, Smart TV, aircondition unit, scanner)

LIBRARY ACTIVITIES

- Conduct of the different library services (Library Orientation, Issuance of Library Cards, reference, borrowing and returning of books, signing of clearance, cataloging, etc.)
- Posting and Sharing of Information in the library webpage
- Preparation of accreditation and CHED-RQAT and NQAT documents
- Celebration of National Library and Information Services Month and National Book Week
- Attended various webinars
- Participation of librarians in the Philippine Librarians Association, Inc. (PLAI) National Congress held in Iloilo Convention Center, Iloilo City

The University's National Service Training Program aims in building the value of patriotism and nationalism among our students. Through the different programs and activities organized by the NSTP Office, CAPSU delivers its contribution to the nation in developing learners through civic consciousness, defense preparedness, and ethical service provided by the trainings of NSTP's component programs.

PATRIOTISM & NATIONALISM



NATIONAL SERVICE TRAINING PROGRAM

4TH QUARTER NATIONWIDE SIMULTANEOUS EARTHQUAKE DRILL 2021

NOVEMBER 11, 2021

College of Engineering & Architecture (CEA) faculty and staff participated in 4th Quarter Nationwide Simultaneous Earthquake Drill 2021.



1ST QUARTER NSED 2022

MARCH 10, 2022
Supreme Student Council Office

- SSC Officers
- CapSU Communication Team
- NSTP/DRRM Staff

1st Quarter Nationwide Simultaneous Earthquake Drill 2022 was participated by Supreme Student Council members and was evaluated by CapSU



NATIONAL SERVICE TRAINING PROGRAM

DUGTONG BUHAY BLOODLETTING PROJECT

MARCH 25, 2022
CITYMall Roxas Avenue

- ROTC Officers
- ROTC staff
- NSTP/DRRM staff

ROTC officers and aspirants participated in Dugtong Buhay Bloodletting Project. The activity was organized by Capiz Information Center of the Philippine Information Agency in partnership with Capiz Police Provincial Office, Bureau of Fire



CAPIZTAHAN 2022

APRIL 22, 2022
Pueblo de Panay

- CapSU Communication Team
- NSTP/DRRM staff

Capiz State University Main Campus faculty and staff were deployed to Capiztahan 2022 as part of communication team during the 2 Day Cycling Road Race MTB & RB Fun Race.

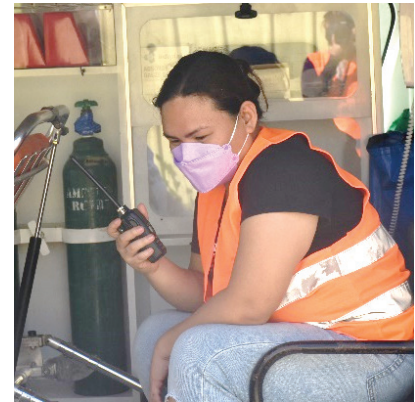

NATIONAL SERVICE TRAINING PROGRAM

PNVSCA CONSULTATION MEETING

JUNE 16, 2022
Central Board Room, CapSU Dayao

- VP for Administration & Finance
- NSTP Director
- NSTP & DRRM Focal Person
- PNVSCA Officials

The PNVSCA Director, sir Donald James Galve and his staff conducted a consultative meeting among the CapSU official and the NSTP/DRRM personnel held at the board room of Central Administration Dayao Satellite College last June 16, 2022.



CADET OFFICERS QUALIFYING COURSE (COQC) CL 02-2022

JUNE 17, 2022
Camp Belo Brgy. Timpas, Panitan, Capiz

- ROTC Personnel
- Tactical Officers
- Tactical NCOs
- ROTC Officers
- ROTC Students
- NSTP/DRRM Staff

ROTC advance Cadets participated in 2 days Cadet Officers Qualifying Course (COQC) at Camp Belo Brgy. Timpas, Panitan, Capiz. The main purpose of the activity is to train cadet through physical, mental, psychological and emotional for them to be prepared for officership.



NATIONAL SERVICE TRAINING PROGRAM

1M KAHÖY PROJECT AND PROVINCIAL ARBOR DAY

JUNE 25, 2022
Camp Escutin Brgy. Matagnop, Dao, Capiz

- CapSU Faculty
- NSTP/DRRM staff

CapSU Main Campus faculty and staff headed by Dr. Wennie F. Legario (VP for Admin. & Finance) joined the 1M Kahoy Project and Provincial Arbor Day held at Camp Escutin Brgy. Matagnop, Dao, Capiz.



Provincial Government of Capiz
Capiz Provincial Environment and Natural Resources Office

Kick-off Ceremony
&
PROVINCIAL ARBOR DAY
Camp Escutin, Brgy. Matagnop, Dao Capiz
June 25, 2022

PROGRAMME

7:00 - 7:05 AM	Opening Prayer	CaPENRO Staff
7:05 - 7:10 AM	Philippine National Anthem	
	Panunumpa ng Katapatan sa Watawat ng Pilipinas	
	Capiz Hymn	
7:10 - 7:20 AM	Welcome Message	Mr. Rodil F. Estrellan Council Secret Executive, BSP Capiz
7:20 - 7:30 AM	Messages	Hon. Rhenz Palomino Brgy. Captain, Brgy. Matagnop, Dao
		Ms. Kristel Jul Rosallo MEMRO Designate, LSU Dao
		Atty. Emilyn Arboleda-Depon Acting CaPENRO
		Hon. Esteban Evan B. Contreras Governor
7:30 - 7:35 AM	Orientation	For. Klua Mariz B. Chavez
	& Instructions	FMS Section Head
7:35 - 7:40 AM	Awarding of the Certificates of Appreciation	
7:40 - ONWARDS	Start of the Tree Growing Activity	

HOST: Mr. Darwin S. Borreros



THE PROVINCIAL GOVERNMENT OF CAPIZ
CAPIZ ENVIRONMENTAL AND NATURAL RESOURCES OFFICE

CERTIFICATE OF APPRECIATION

is given to

Capiz State University

For the valuable support to the 1M Kahoy Project, an annual annual tree-planting event of the Province of Capiz, and for joining this year's Kick-Off Ceremony at Camp Escutin, Brgy. Matagnop, Dao, Capiz.

Given this 25th day of June 2022 at Camp Escutin Brgy. Matagnop, Dao, Capiz, Philippines.

ATTY. EMI-LYN ARBOLEDA-DEPON
Acting CaPENRO

ESTEBAN EVAN B. CONTRERAS
Governor

Kick-off CEREMONY



MOVE FORWARD

Despite the many challenges of the stricter protocols and restrictions brought about by the increasing number of cases and the discovery of the new variant at the beginning of the year, the office of External Affairs and Linkages continue to move forward, provide creative ideas to implement, virtual discussion with partners about possible activities.

Through hard work and determination, the following were accomplished by the office from January to April 15, 2022.

EXTERNAL AFFAIRS AND LINKAGES

FACULTY EXCHANGE PROGRAM CLOSING CEREMONY

Following the successful exchange of the lecturers last October 25, 2021- December 23, 2022, the closing ceremony of the Faculty Exchange Program was conducted hosted by the Universitas Ahmad Dahlan University last January 19, 2022.

The Exchange aimed to meet the following objectives:

- to enable lecturers to enhance their teaching skills and pedagogy
- to give lecturers opportunities to gain a broader regional and world view
- to expose lecturers to diverse teaching and learning situations and opportunities

Efforts to Expand International Networks Through Exchange of UAD Lecturers with CAPSU

By your media - 20 Jan 2022



12 Shares



YOGYA – The lecturer exchange program between Ahmad Dahlan University (UAD) and Capiz State University (CAPSU) in the Philippines was closed, Wednesday (19/1). The closing ceremony was carried out by the Rector of UAD, Dr. Muchlas, MT, and President of CAPSU, Dr. Editha C. Alfon.

This event was attended by Dr. Trikinasih Handayani, M.Sc. (Dean of the Faculty of Teacher Training and Education) and Dr. Budi Hartanto, M.Pd.

The Yogyakarta local news team featured the closing ceremony of the UAD and CAPSU Faculty Exchange Program last January 19, 2022.

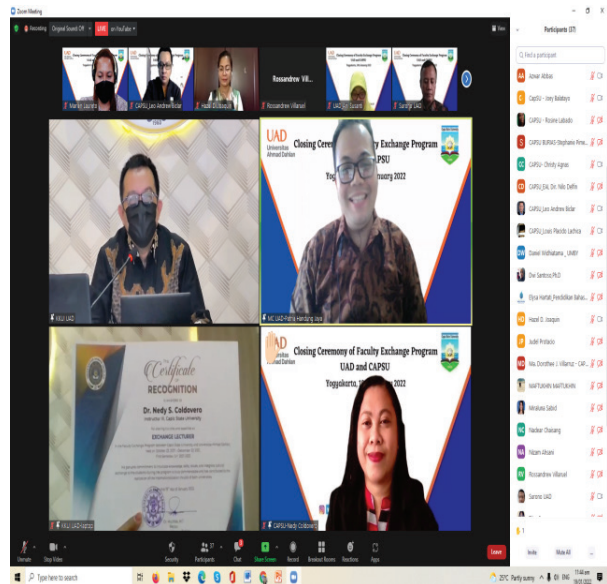

Dr. Nedy Coldovero, one of the exchange lecturers from CAPSU, was awarded Certificate of Recognition during the Closing Program. The certificate was given by the UAD Vice Rector for Academic Affairs- Dr. Rusydi Umar. The same award is given to the rest of the exchange faculty program participants.

ESTABLISHED LINKAGES AND PARTNERSHIPS

Recognizing the significance of linkages and partnerships locally and internationally, the office has never ceased to create partnerships towards potential partners.

The following are the established linkages since January 2022.

- Institute of Electrical Engineers United Arab Emirates Chapter- January 7, 2022
- Institute of Integrated Electrical Engineers of the Philippines, Incorporated- Kuwait Chapter- January 28, 2022
- United Architects of the Philippines – Qatar Chapter- February 23, 2022
- Philippine Society of Mechanical Engineers- Qatar Chapter- February 23, 2022
- National Master Plumbers Association of the Philippines- Qatar Chapter – February 23, 2022
- Luna Academy, Inc- January 23, 2023
- National Master Plumbers Association of the Philippines (NAMPA) Qatar Chapter
- Philippine Society of Mechanical Engineers (PSME) Qatar Chapter
- United Architects of the Philippines (UAP) Qatar Chapter
- Japan Hospitality Learning Center (JHLCA)
- Universitas Muhammadiyah Kotabumi, Indonesia (UMKO)
- Pangkep State Polytechnic of Agriculture (POLIPANGKEP), Indonesia
- International Cultural Communication Center Malaysia (ICCCM)
- Go Study Global Education Groups (Prc) Co., Limited, China (Go Study)

FACULTY MOBILITY AND ACTIVITIES

SEARCA- LevelUPHEI AFAR

CAPSU joined the University Consortium of the Southeast Asian Regional Center for Graduate Study and Research in Agriculture (SEARCA) funded by the Commission on Higher Education (CHED) project Leveling Up Philippine Higher Education Institutions in Agriculture, Fisheries, and Natural Resources (LevelUPHEI AFAR). With this, 5 faculty members from the College of Agriculture qualified for the program and They are to be hosted by Institut Pertanian Bogor (IPB) in Bogor, Indonesia. The following are the successful applicants: Dr. Rey Dela Calzada, Prof. Gelene Alvarez, Prof. Jon Verny Biaco, Prof. Emily Escala and Prof. Martin Ton-ogan from the College of Agriculture and Fisheries of the Pontevedra Campus. They are scheduled for the Faculty Mobility for the Academic Year 2022-2023.

Webinars with Faculty as Resource Persons

Through the linkages established, CAPSU faculty members were invited as resource speakers for the conducted webinars in Indonesia: **Dr. Rossandrew Villaruel of the Pontevedra Campus**, and **Dr. Gerard Atienza of the Burias Campus** were invited as Guest Lecturers in Universitas Ahmad Dahlan Faculty of English Education last January 15, 2022.

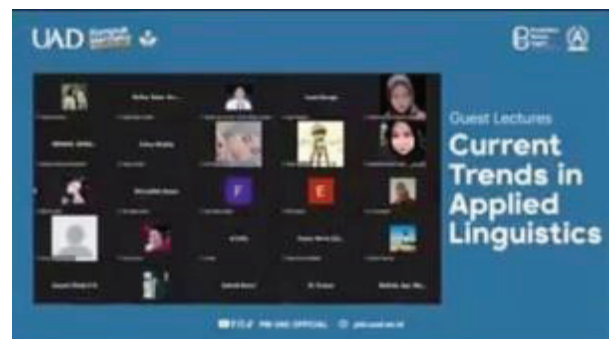
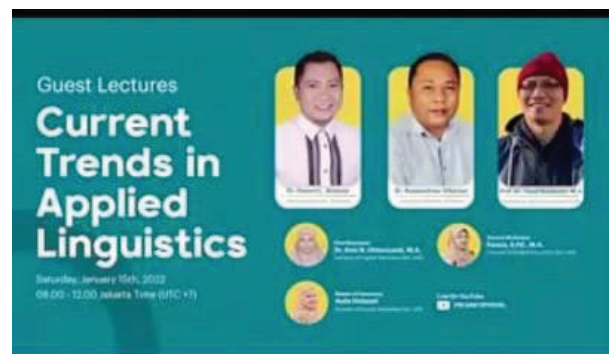



■ **Indigenous Peoples Day Celebration - (August 9, 2022)**

The university participated in the celebration of the Indigenous Peoples Day Celebration through a poster campaign indicating the University's message through Dr. Alfon in support to women and indigenous Peoples. This was also the first time that the university has conducted a formal photo opportunity for the President as a first step of the university in the efforts towards establishment of its good marketing and branding.



■ **Institutional Strategic Partnership, Expansion of the Internationalization of CAPSU (August 30, 2022)**

As the university embarks in a bolder Internationalization journey, it has to capitalize and establish institutional strategic partnership and expansion giving emphasis on research- based management and governance, quality of teaching and learning, quality of professional exposure, research and creative works, and relation with the community.

With this, the EAL Office co- facilitated with the RDE Office the Institutional Strategic Partnership, Expansion of The Internationalization of CAPSU on August 30, 2022 at the Accreditation Room at 8:30AM- 5:00PM. The activity was attended by the Key Officials of the whole CAPSU System. Dr. Yazrina Yahya of the Universiti Kebangsaan Malaysia was the invited guest speaker who taught about the essence of the IZN as well as the benefits a university will have when all of its members cooperate and work as one. She then proceeded with the Key Responsibilities of Pro Vice Chancellors/ Deputy Vice Chancellors/ Deputy Vice Chancellors/ Deputy President International affairs, who will play a central key member of the university's realizations of the goals and strategic plans and actions and who got a big role in the development & implementation of the university's international strategy to raise the presence, profile & reputation of the institution as well as lead the achievement of targets and outcomes in relation to international partnerships, research, and educational activity. They become the lead movers of the internationalization of the university.



EXTERNAL AFFAIRS AND LINKAGES

- UAD Short Course On Indonesian Legal System 2022**
July 26, 2022- August 15, 2022

Capiz State University-Office of External Affairs and Linkages fuels international partnership with Universitas Ahman Dalan-Indonesia through 14-day short course program, spearheaded by UAD-Faculty of Law.

Sixty university students from CapSU-Roxas City, Dayao, Pontevedra, Burias and Dumarao campuses attended virtual Zoom discussion from July 26 to August 15, 2022.

With the theme "Understanding the Laws and Legal Culture in Indonesia", CapSUnians learned Indonesia's political history and its three legal systems: civic law, customary law and Islamic law.

CapSU-EAL emphasized that the recently concluded international program assisted the office in reaching its goal towards producing globally competitive graduates.

"These international privileges pave ways to new learning. While it is expected for the participants who majored in Social Studies to enhance their knowledge on the laws and culture of the Indonesian community, this course expands their perception of the society and appreciate the culture of others. In addition, participants were also expected to have learned teaching pedagogies which are applicable in their own fields", the office stated.

The students elaborated intercultural approach; simplifying depth concept and respect as teaching strategies he acquired throughout the learning process. Though the course they learned diverse teaching strategies which they can apply as a future educator: the necessity to use intercultural approach where teacher value students' cultural differences; simplifying breadth and depth of concepts by using a graphic organizer and flow chart can explain concepts clearly and make things easier to understand; and that the teaching approach should be 'learner-centered' and 'respect' must be the heart of instruction to provide inclusivity where learners feel safe, belong and free from many judgment"



- ***CAPSU Participation on the 55th ASEAN Anniversary Celebration September 25-30, 2022***

In line with the 55th Founding Anniversary of the Association of Southeast Asian Nations, this university, in cooperation with the Higher Education Institutions in Panay and Guimaras Islands, is joining an ASEAN EXHIBITS to be held at Robinson's Place, Jaro, Iloilo City on September 26-30, 2022.

During the ASEAN exhibit, CAPSU was assigned to represent MALAYSIA. With this, the EAL Office co-facilitated along with the Office of the Academic Affairs the conduct of the said activity and assigned the different committees involved during the week-long activity.

Each of the campuses was able to participate as they get to exhibit their campus products as they are scheduled for display as well as showcase their own adaptation of the Malaysian Cuisine which they offered for free-tastes to all guests visiting the booth during the 5-day exhibit.



The Key Officials of the University lead by Dr. Editha C. Alfon, University President, attended the Opening Ceremony of the ASEAN. Photo taken in front of the CAPSU Booth representing the country of Malaysia

EXTERNAL AFFAIRS AND LINKAGES

- **CAPSU and JHLCA MOU Signing, General Orientation and Interview Oct. 17-19, 2022**

As the university faces the new normal education, it wishes to provide more opportunities to students adhering to its objective- to produce globally competitive graduates.

With this, the Office of External Affairs and Linkages managed to forge partnership with Japan Hospitality Learning Center Association through MOU Signing last October 17, 2022. The main objective of the partnership is to provide on the job training to the qualified students. Mr. Kazutaka Nakao, CEO of JHLCA personally came to the Philippines to meet the qualified students in the BSHM, BS Tourism, BS Agriculture and BS Civil Engineering Students. During his visit, he was able to meet and greet and Local Government heads Gov. Ferdinell Castro and Mayor Ronnie Dadvivas. Prior to the all- expense paid internship deployment, MR Nakao offered a free Japanese Language Training to all students who wish to go to Japan in the future for work.

The first batch of the 120 students are bound to fly to Japan for their internship in February 2023.

- **ATTENDANCE TO ANTENA of REPLICATION WORKSHOPS AT NATIONAL LEVEL TRAINING**

In connection to the invitation of the Commission on Higher Education- ANTENA Erasmus+ Project, the Campus EAL Chairpersons joined the ANTENA Replication of Workshops at National Level Training on November 15-17, 2022 at 8:00 AM-5PM. The said training was conducted to train the trainers in the maze of internationalization projects and programs. The 3 day- workshop focused more on the following topics: Strategic Planning, International Networking and Opportunities, Fundraising and Project Management and the like which aimed to enrich the people in the universities who work behind internationalization programs of their institutions.



*The RDE Office, through its Research,
Extension, Training, and IPMO
offices had conducted relevant to the
expected deliverables of the office.*

**AIMED TO
CAPACITATE**



INTRODUCTION

RESEARCH OFFICE

The Research Office had crafted its three-year agenda and five-year roadmap last April 20, 2022, which aimed to boost the internationalization of research engagements, and commercialization of the outputs of the faculty researchers. With the implementation of the researches, a ceremonial signing of the research agreement among the faculty was conducted. The RDE office had also conducted its first quarter meeting held at the various campuses to assess the accomplishments of the campus/college accomplishments in terms of research and extension.

- **Externally Funded Programs and Projects.** The Research Office continuously monitors and supervises the 12 externally funded research programs and projects funded by DA-BAR, DA-RO6, DOST-PCAARRD, CHED-IAS, USDA, and other partner agencies.
- **Data on Patent Filing.** A total of three (3) technologies were filed as patent, two (2) for Utility Model, and among the 45 technologies applied for copyright, 35 were registered while 10 were still in the process of an application.

TRAINING OFFICE

The RDE Training Office facilitated the journal writing and preparation for publication workshop. The workshop aimed to capacitate the faculty researchers in submitting their research articles for publication in Scopus/ISI refereed journals.

INTELLECTUAL PROPERTY MANAGEMENT OFFICE (IPMO)

The IPMO, through its DOST-PCAARRD-CAPSU ATBI Project, had catered to the learning visits and benchmarking activities of some SUCs in the region to look into the best practices, policies, and strategies. Among the SUCs visited the project are the TUPV, CPSU, ASU, UPV, and Hublag Foundation. Moreover, CAPSU, through the RDE IPMO had been recognized by the IPOPHIL as the Top Utility Registrant from 2017 to 2021 and Second Place - Top ITSO Filer from 2016 to 2021 on June 6, 2022, as part of its 25th Anniversary Celebration.

The RDE conducted its annual PAGTUKIB expo which focuses on the various food and beverages products from the different campuses, satellite colleges, and incubatees from the Agri-Aqua Technology Business Incubator (ATBI) and Agribusiness Incubator (ABI) of Capiz State University. Tradeshows, cooking competitions, and technology pitching were the highlights of the event.

A Utilization forum was done for the Riverine Improvement towards a Sustainable Ecotourism in Roxas City, Capiz, Philippines (RISE Capiz) Project. The forum was attended by the beneficiaries of the project, namely: the palina and Cadimahan River Tour Operators.

COMPLETED RESEARCH

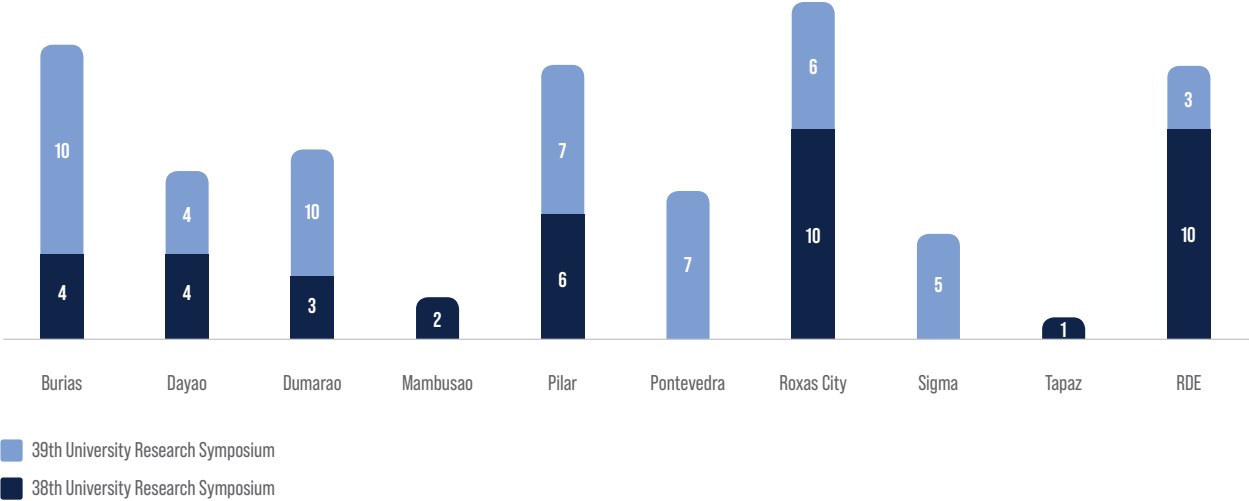

The University faculty-researchers have produced a total of 75 researches for the year 2022, a significant spike from the slump brought about by the pandemic. This only indicates that the University is once again on track to its commitment of producing quality researches and nurturing an environment that breeds inquisitive minds and development-oriented learners.

FUNDED PROJECTS

ON-GOING FUNDED PROJECTS

1. R.I.S.E. Capiz (Riverine Improvement for Sustainable Ecotourism in Roxas City, Capiz)
2. Enhancing the Agri-Aqua Food Value Chain through Smart Technologies and Partnerships towards Food Resiliency in the New Normal
3. RD Lead Program
4. Establishment of DA-BAR CAPSU Agribusiness Incubator
5. Development of Pineapple Stripping Machine
6. CAPSU Agri-Aqua Technology Business Incubator (Phase 2)
7. From Substrates to Utilization: Ensuring Vermicompost Quality and Safety

NEWLY APPROVED FUNDED PROJECTS

1. Adoption of Mangrove Crab Hatchery Seed Production and Nursery Facility in Pilar, Capiz
2. Province-led Agriculture and Extension System (PAFES)
3. Plant Nursery
4. Coffee Demo Farm
5. Regional Agri Aqua Innovation Enhancement (RAISE) Program in Western Visayas
 - Project 1. Regional Intellectual Property and Technology Management (IP-TBM)
 - Project 1A. Enhancing Technology Transfer through RAISE in Capiz State University
 - Project 3. Regional Agri-Aqua Technology Incubator (ATBI)
 - Project 3A. DOST PCAARRD-CAPSU Agri-Aqua Technology Business incubator (ATBI)
6. Innovations Laboratory for Process Machinery and Related Technology Development (i-Lab ProMaTech)
7. Expanding the Operation of the DA-BAR TBI Program of CAPSU (Phase 2)
8. Sustainably Acceleration and Fostering Equitable Fishery Market Engagement in Pilar Bay, Capiz (SAFE Project) - Partnership with SIKAT (Sentro para sa Ikaunlad ng Katutubong Agham at Technolohiya), Inc.
9. Establish a Qualisafe Lab thru Upgrading of Microbiology Laboratory at CAPSU Dayao Campus and Physico-Chemical Laboratory at Mambusao Campus
10. Enhancement, Pilot Testing and Market Study of Biomass-Fried Dryer
 - Project 1. Regional Intellectual Property and Technology Management (IP-TBM)
 - Project 1A. Enhancing Technology Transfer through RAISE in Capiz State University
 - Project 3. Regional Agri-Aqua Technology Incubator (ATBI)
 - Project 3A. DOST PCAARRD-CAPSU Agri-Aqua Technology Business incubator (ATBI)

PATENT FILING

Title of Technology	Application No.	Date of Filing	Name of Inventor/s
Biomass-Fired Bed-Type Dryer	1/2020/050152	04/14/2022	Oloroso, Monalyn L., Albaladejo, Julito A, Linan Efren L, Lavado, Mae Ann L, Salvador, Donn Jester
Roller Type Slitter and Presser Machine for Fruit Extraction	1/2022/05034	06/30/2022	Monalyn L. Oloroso
Coconut Dehusker	1/2022/050588	11/27/2022	Delfin Marty C., Olisco Mary Ann L., Diaz Rose Shane A.

UTILITY MODELS

Title of Technology	Application No.	Date of Filing	Name of Inventor/s
Chlorella Enriched Pandesal	22022050720	09/09/22	Abner F. Orofeo
Process of Producing Chlorella Enriched Pandesal	22022050721	09/09/22	Abner F. Orofeo

CAPSU to implement Rapid Appraisal of PAFES

On February 16, 2022, an inception meeting was in Iloilo City in which Capiz State University (CAPSU) is one of the three (3) SUCs in the region to implement the Rapid Appraisal of the implementation of the Province-led Agriculture and Fisheries Extension System (PAFES).

The PAFES is one of the 18 strategies of the Department of Agriculture (DA) to carry out its "One DA Reform Agenda." The PAFES will strengthen the collaboration between DA, local government units, academe, and private sector. The PAFES will be institutionalized to bring extension services to the grassroots level amid the challenges of devolution. With PAVES

The ceremonial MOA Signing was highlighted in the meeting where Dr. Pablo Crespo, President of the University of Antique, was present in the meeting while Dr. Efren L. Linan, CAPSU Vice President for Research Development and Extension represented Dr. Editha C. Alfon, the University President; and Dr. Greta Gabinete, VP for Research, Extension, and Training represented the West Visayas State University.

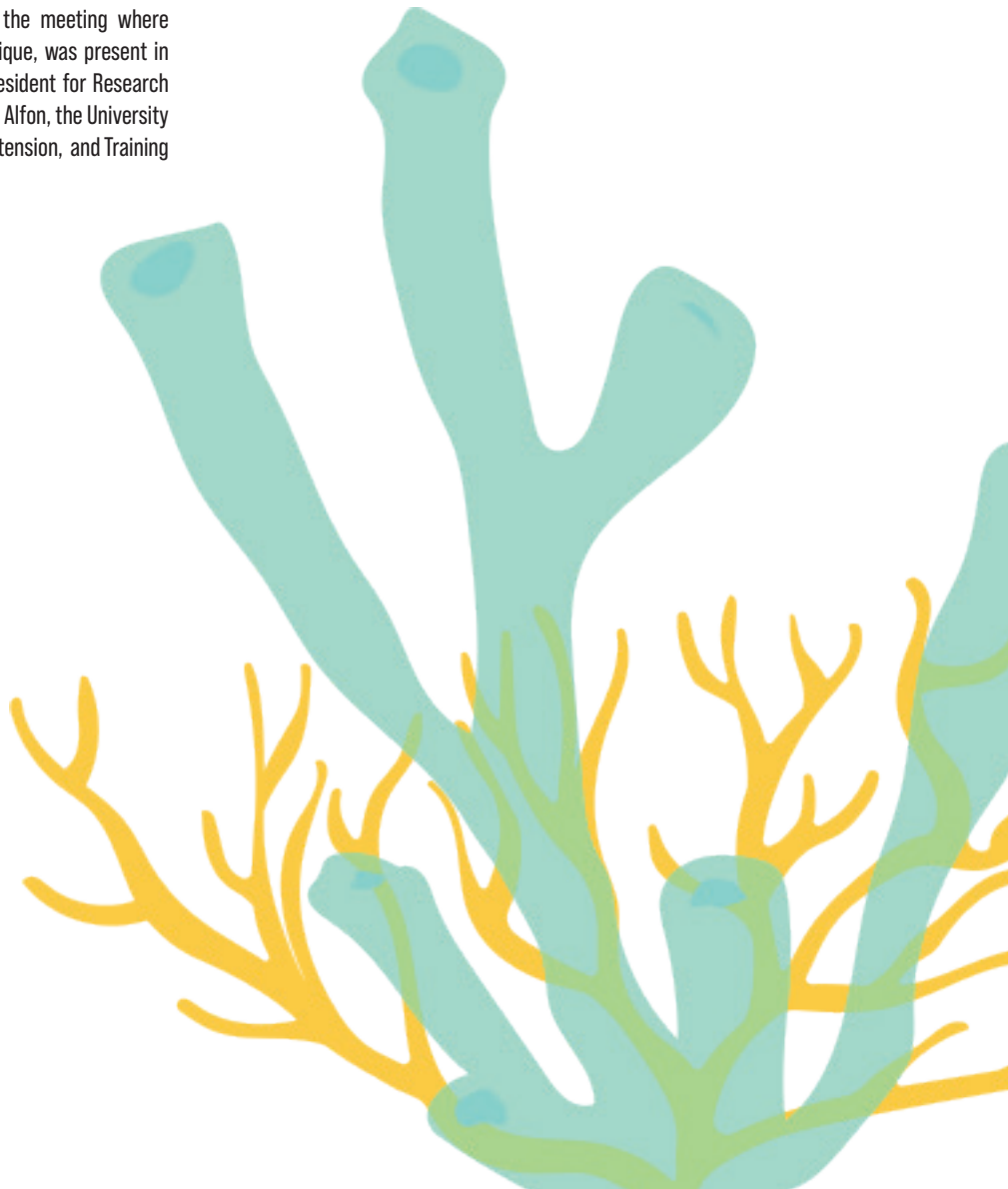

CAPSU Philcafe Project Team assesses coffee farmers in Dumarao



CAPSU faculty researchers conducted the pre-assessment activity for some coffee growers/farmers on February 18, 2022, at Dumarao, Capiz.

The key informants during the assessment were Salvador Escona, Ati Community Chieftain in Sitio Tag-aw, Tamulalod, Susan Hidama, Tamulalod Progressive Farmers and Producers Association President, and Larry Saldivia Coffee Farmers President in Brgy. Taslan.

Rejuvenation of the coffee plantations, the presence of the middlemen, and low-costings of coffee production were among the significant challenges encountered by the associations. Although Mrs. Hidama had acquired some post-harvest equipment from several NGOs, she finds it more challenging to supply the high demands of the consumers who come to their association in Tamulalod and buy their processed coffee.

With the pressing situations of the coffee farmers in Dumarao, Capiz, the CAPSU Team will soon conduct some interventions in these communities through Philcafé Project implementation.

Dr. Aljen P. Vasquez, Science Research Specialist II of the Department of Agriculture-Western Visayas stationed in Capiz Research Outreach at Dumarao, assisted the CAPSU researchers.

The CAPSU Team, on the other hand, was represented by Ramonita Verano, Extension Chair (Burias Campus); Engr. Monalyn Oloroso, Research Chair (Burias Campus); and Dr. Leo Andrew Biclar, Research Director.

RDE HOLDS ITS 1ST QUARTER MEETING FOR 2022



The Research and Extension Chairs, Center Directors, and the RDE Office of CAPSU held its 1st Quarter Meeting last March 15 (Extension Offices) and March 16 (Research Offices) at the FFRDC Conference Room, CAPSU Dayao, Roxas City, Capiz.

During the meeting, the Research and Extension Offices took their turns in reviewing the accomplishments of their respective offices.

RDE Office achieves more and more goals over the years. The office also needs to find new ways in order to increase the productivity of all the campuses and offices in terms of research through new innovations and modern technology.



CAPSU RDE conducts 5-year Agenda Setting and Roadmap Development for Research



Capiz State University conducted an RDE 5-Year Agenda Setting and Roadmap Development for Research, Extension, and IPMO last March 21-22, 2022.

The first day of the agenda-setting and roadmap development was participated by the university's research center directors and the faculty experts on the different research disciplines. The second day of the event was participated by the campus administrators, satellite college directors, research chairs, extension chairs, faculty researchers, and extensionists.

The activity's purpose was to plan a solid roadmap that will serve as the foundation of the RDE agenda of CAPSU as a whole. It begins at the most basic conceptualization up to the internationalization of the research and extension activities that will be conducted.

In summary, it gives CAPSU one major vision to be focused on its next 5-year operations.



DEFINING OUR VISION OF EXCELLENCE



CONGRATULATIONS!

Capiz State University

Research, Development and Extension Office
through its Intellectual Property Management Office (IPMO)

as the **Top Utility Model
Registrant from 2017-2021**
and
2nd Place - Top ITSO Filer
from **2016-2021** awarded by the
Intellectual Property Office of the
Philippines (IPOPHL) on June 6, 2022.



Capiz State University has been recognized by the Intellectual Property Office of the Philippines (IPOPHL) as the Top Utility Registrant from 2017 to 2021 and Second Place - Top ITSO Filer from 2016 to 2021 as part of its 25th Anniversary Celebration with the theme Rising at 25: Creating a Silver Bright Future last June 6, 2022. The awards were received by Prof. Mark Glenn F. Villamor, IPMO Director, on behalf of Dr. Editha C. Alfon, University President.

The descriptions of the awards are as follows:

- Bronze - For integrating and offering a three-unit Intellectual Property (IP) subject in its academic curriculum.
- Silver - For having provided 24 patent search services in 2021.
- Gold - For having drafted and filed seven (7) invention patents in 2021.
- Platinum - For having drafted and filed seven (7) invention patents and successfully commercialized its Utility Model entitled "Botanical Dewormer" through a Licensing Agreement with BDOZ Veterinary Products Training.

CAPSU GAINS NEW FUNDED PROJECTS



In a ceremonial signing of the Memorandum of Agreement (MOA) between the Capiz State University (CAPSU) and the Department of Science and Technology- Philippine Council for Industry, Energy and Emerging Technology Research and Development (DOST-PCIEERD), two (2) new projects were approved for CAPSU for funding on October 4, 2022, at the Venice Grand Mall, Taguig City.

The two (2) projects were the Innovations Laboratory for Process Machine and Related Technology Development (i-Lab ProMaTech) led by Engr. Monalyn L. Oloroso and the Quali-Safe Lab: Food Quality and Safety Laboratory for Seafoods and other Innovative Food Products led by Dr. Marife R. Hilapad.

The projects were approved under the Infrastructure Development Program (IDP) of DOST-PCIEERD which will be implemented for two years

FACULTY RESEARCHERS LEARNS PACKAGING, LABELING AND GRAPHIC DESIGN FOR CAPSU TECHNOLOGIES



CAPSU campuses and satellite colleges sent representatives for the Training on Packaging, Labeling, and Graphic Design for CAPSU Technologies on October 11-12, 2022 at the Technology Business Center, Dayao, Roxas City, Capiz.

The activity is a collaborative effort of the University's Research, Development and Extension (RDE) Office and the CAPSULE TBI.

In his opening message, Dr. Efren L. Linan, CAPSU VP for RDE, encourages the faculty participants to submit a proposal to agencies for possible funding for a research project. These initiatives will not only benefit CAPSU but also the participants' professional growth as well.

During the training, it was emphasized that the packaging and labeling are integral in marketing the products they sell. Proper use of packaging materials must be observed in order to get noticed. Graphic design, on the other hand, will supplement the packaging in communicating the product.



HIGHLIGHTS OF RDE ACTIVITIES



CAPSU RDE EXECS CONNECT WITH THAI BISPA AND KASETSART UNIVERSITY

Capiz State University Technology Business Incubator delegation headed by Dr. Efren L. Linan, VP for RDE, together with his team, Dr. Leo Andrew B. Bicular, University Research Director, Mr. Mark Glenn F. Villamor, IPMO Director and Planning Officer, Dr. Marien A. Laureto, International Linkages Director and Mr. French A. Dampog, IPMO KTTD Chief attended the ASEAN Integration and Networking on Business Incubators and Science Parks (BISPA) and Institute of Food Research and Product Development of Kasetsart University in Thailand on October 25-27, 2022.

With this, the team were able to learn new insights on how Thai BISPA were able to manage and sustain their incubation program through the linkages and partnerships they have established with the Thai government, private and public sectors, academic institutions and SMEs.

The team also proposed a partnership to the Kasetsart University through students and faculty exchange as well as possible research collaborations.

CAPSU RESEARCHERS PLUNGES INTO NANOTECHNOLOGY



Capiz State University partners with the University of the Philippines Visayas to train the faculty researchers of CAPSU on Nanotechnology for Agri-Aqua: Research Innovation Network and Green Process for Marine Nanomaterials on October 17-19, 2022 at the CAPSU Technology Business Center and a chance to visit the UPV Nanotechnology Facility in Miagao, Campus on October 20, 2022.

Dr. Concepcion P. Ponce, Dr. Ricardo Babaran, Ms. Hannah C. Valencia, and Ms. Chenille Siva served as the resource persons for the said event.

The resource persons introduced the disciplines of nanotechnology that are connected with many branches of natural and biological sciences.

They also taught how to write capsule proposals, how to search for possible research opportunities through patent and utility model searching, how to prepare the work and financial plan, and how to package the proposals accordingly for submission to the partner agencies of CAPSU.

The resource persons introduced a variety of tools and equipment used in nanotechnologies during the site visit at the UPV Nanotechnology Facility. The participants gain a hands-on experience using the various tools and equipment for nanotechnology and the results of the tests will be integrated in their ongoing researches.

CAPSU RESEARCHERS PLUNGES INTO NANOTECHNOLOGY



A training on establishing a spin-off companies in the SUCs | Nov 10 - 11, 2022

DOST VI Technology Transfer Unit, in collaboration with Iloilo Science and Technology University (ISAT U), Capiz State University (CapSU), and West Visayas State University (WVSU) presents the “Establishing the Spin-off Co.”, a training workshop in establishing spin-off companies in the Region VI State Universities and Colleges (SUCs) on November 10-11, 2022 at Circulo Convention Center, Roxas City, Capiz.

The hybrid face-to-face and virtual training-workshop aims to answer issues and problems that the different SUCs in the region encounter in the commercialization of SUC-developed technologies through the creation of spin-off companies.

In the region, there were already four (4) spin-off companies, including Algacon Feeds Manufacturing and Roselient Processed Food Manufacturing from UP Visayas, BDOZ Veterinary Products Trading, and D’ Alfincoles Food and Beverage Trading from CAPSU.

DOST VI and collaborating technology transfer teams from ISAT U, CAPSU, and WVSU hope to encourage the researchers and other SUCs to commercialize the technologies to enable the mechanism for the STI community to keep up with the rest of the world in terms of innovation and economic progress.

**TWO (2) OF CAPSU TECHNOLOGIES
THAT WERE FILED FOR PATENTS WERE
APPROVED IN 2022.**

PLANTAIN CHIPPER

1/2016/000094

Inventor:
Pedro M. Celo

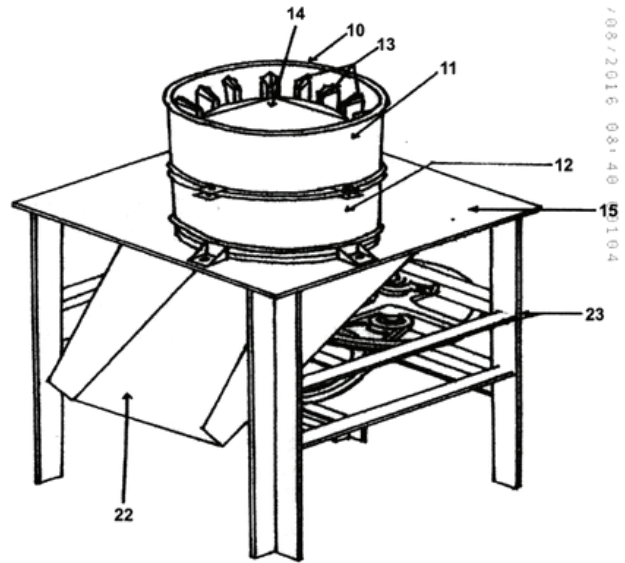



Figure 1

PEDRO M. CELO
Inventor/Applicant
FORTUN NARVASA & SALAZAR
Agent
By: 
BAYANI B. LOSTE

TWINING MACHINE

1/2019/050261

Inventor:
**Marilyn Bernabe
Julito Albaladejo
Monalyn Oloroso
Michelle Villamor
Willard Opher**

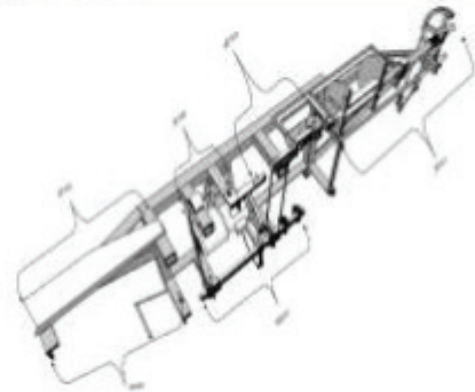

CESO ideates to deliver a full and pertinent pool of information and activities that will motivate the community toward sustainable development. Partner agencies and stakeholders have significantly changed and affected the Extension dynamics needed during the COVID-19 pandemic. The new normal means embracing the reality of the digital world, being innovative, and exploring the use of digital platforms in the delivery of extensions around Capiz.

EMBRACING THE REALITY



EXTENSION SERVICES | HIGHLIGHTS

The Community Extension Services Office (CESO) of Capiz State University are implemented through agreements and partnerships with government agencies, non-governmental groups, nonprofits, and private enterprises to help localities become financially sustainable and self-sufficient, thereby addressing various communal needs and challenges. CESO ideates to deliver a full and pertinent pool of information and activities that will motivate the community toward sustainable development. Partner agencies and stakeholders have significantly changed and affected the Extension dynamics needed during the COVID-19 pandemic. The new normal means embracing the reality of the digital world, being innovative, and exploring the use of digital platforms in the delivery of extensions around Capiz.

Since the onset of the community quarantine period, a total of three hundred fifty-five (355) Projects, Programs, and Activities (PPAs) were conducted and initiated by different campuses and satellite colleges, benefitting a total of 15, 491 individuals comprised of recipients from the university, community, and other partner agencies as well, across the region. The participants and beneficiaries were given technical information and tangible assistance, which helped them reconsider opportunities and recover from the pandemic's current situation. Nevertheless, CAPSU faculty extension implementers have paved the way in continuously helping uplift the life of the community members.

Moreover, ten extension programs/projects were presented during the 38th CAPSU RDE Midyear Hybrid Conference last August 22 – 23, 2022. It was critiqued by external evaluators like Dr. Corazon C. Corbal, Vice



President, Academic Affairs, ISAT University, Dr. Vilama M. Patindol, Former R08 ATI Director, and Dr. Ramises N. Solante, Former Faculty, CAPSU Burias. Winners are the following:

Best Paper: Project BUILD (Barangay Unification for Innovative Learning and Development) for Calamansi Juice Processors in the Province of Capiz by Monalyn L. Oloroso, Ramonita C. Verano, Marilyn L. Bernabe, Efren L. Linan, Julito A. Albaladejo, Stephanie S. Pimentel, Merry Flor L. Martinez, Dave Mitchelle S. Lantoria – Burias Campus

First Runner Up: ALAY-Kaunlaran's TREAT-U: Corn, Coconut, etc by Marty Delfin, Abelardo Bermejo, Bonifacio Hontiveros, Sandra Balsote, Catherine B. Arroyo, |Alex D. Buenafe, Kenny John P. Ballera, Francis Belle Lampong – Pontevedra

Second Runner Up: School Away from School: Pag-ulikid kag Pagsakdag sa mga Kabataan Ginikanan kag Lideres by Mary Ann Decrepito, Matilde C. Tonel, Aleta Rose Onglatco, Sandra Escabarte, Cheryl Gicana, Fe Mae Laborte, Edwin Daliva, Jerelyn De Pablo, Virginia Figueroa, Shawn Dacles, Krotchive Apolinario - Pontevedra

Also, three (3) extension programs/projects were presented during the 39th University RDE Year-End Symposium on November 29, 2022. External evaluators justifiably commented on them: Dr. Corazon Corbal, VP of Academic Affairs of ISAT University (Iloilo City); Prof. Juniel Lucidos, Director of Planning and Development of Romblon State University, and Dr. Emelita P. Solante, Former CAPSU Extension Director. Winners of the said activity are as follows:





Best Paper: PROJECT KBP: Kapon bakuna kag Purga sa Ido kag Kuring by: Maryneth B. Barrios, Leah A. Ingalla, Aveguin Miguello, Nelinda V. Duero – Burias

First Runner Up: Gawad Kalinga: An Assessment of the Community Extension Program by Emmanuel D. Dayalo – Roxas City Main

Second Runner Up: Unnnnnnnnn of Paper Waste Materials Into Handicraft Product as Livelihood Project and Waste Management Segregation by: Warren S. Celoso, Gemma Angelias, Dennis Ledesma, Ma. Consuelo Y. Yap, Matilde C. Loyola, Ma. Lida Solano – Roxas Main Campus

Fifteen (15) CAPSU Extension Implementers attended the *11th PASUC VI-Extension Managers Council, Inc. Regional Symposium and General Assembly* with the theme: “Advancing the Role of Extension Implementers Amidst Adversities towards Sustainable Development” held last November 8 – 10, 2022, at Northern Negros State College of Science and Technology (NONESCOST) Sunn Hotel, Sagay City, Negros Occidental. **Engr. Monalyn L. Oloroso** presented her paper entitled **Project BUILD** (Barangay Unification

for Innovative Learning and Development] for Calamansi Juice Processors in the Province of Capiz and won the **2nd Runner Up in Agriculture, Fisheries, and Livelihood Category.**

The pandemic may have changed the landscape of how we learn. Still, the purpose of education remains the same – that is, for the beneficiaries to apply what they have known for the greater good of the community and uplift their status of living.

Throughout the years, it has been part and parcel of the institution to aid the community even through great and dangerous odds. The extensionists of CAPSU had to focus on recovery, reclamation, and rebuilding what had been lost to the grasp of the pandemic. This 2022, the institution will now be focusing on sustainability, growth, and the development of the people of Capiz.

Now, CAPSU is looking forward to fully integrating the extension efforts of its faculty and staff into the academic experience of its students. This will give our students a sense of duty and honor while studying their courses and, at the same time, being able to take part in helping the community of Capiz.

EXTENSION SERVICES | HIGHLIGHTS

MAIN CAMPUS



Skills Training on Food Technology
Barangay Culajao, Roxas City
December 10-18, 2022



Skills Training on Handicraft
Barangay Culajao, Roxas City
December 10-11, 2022



MAIN CAMPUS



Skills Training on Small Engine Repair and Servicing
Barangay Culajao, Roxas City
December 10-22, 2022



Skills Training on Building Wiring Installation
Trainer: Engr. Ronnel P. Babis
Brgy. Cogon, Panitan, Capiz last February 19-March 6, 2022



Distribution of Kabuhayan Starter Kit
Brgy. Jumaguicjic, Roxas City last June 2, 2022

EXTENSION SERVICES | HIGHLIGHTS

MAIN CAMPUS



Skills Training on Refrigeration and Airconditioning
Barangay Jumaguicjic, Roxas City
November 19-December 18, 2022



Skills Training on Beauty Care
Trainer: Prof. Nelma P. Delos Santos
Brgy. Quiajo, Pres., Roxas, Capiz
July 11-16, 2022



Skills Training on Welding
Trainer: Prof. Jude Maquiran
Brgy. Quiajo, Pres., Roxas, Capiz
July 11-16, 2022

PONTEVEDRA

Photo opportunity with the key officials, speaker and facilitators during this two-day activity taken at the façade of the CPC Annex Bldg., Arnaldo Blvd., Roxas City



During the operation and demonstration of the BSABE Coconut Dehusker.



During the operation and demonstration of the BSABE Coconut Grater and Grinder

EXTENSION SERVICES | HIGHLIGHTS

PONTEVEDRA

Prof. Kris B. Roxas delivering her lecture regarding the process of liquid hand soap making.



Actual hands-on and demonstration of the participants.

PONTEVEDRA

The participants enjoyed placing some labels for their finished product - The Bangus Tomato Sardines



Photos were taken during the actual demonstration of the participants. Prof. Leah Yakit served as the resource person. Prior to the demonstration, Prof. Yakit provided lectures regarding the importance of proper hygiene and sanitation. She also tackled some short background with regard to the rationale of the training.

EXTENSION SERVICES | HIGHLIGHTS

PONTEVEDRA

Ret. Prof. Cleopatra Amante served as the lead trainer for this activity. She was assisted by Prof. Jonan P. Burgos, Prof. Leah Yakit & Mr. Mark Borines.



Training on Siomai and Meatball Processing last September 10, 2022

SIGMA

The professors who joined the Trainers' Training in Brazo De Mercedes Making worked by pair in making the sweet delight.



Prof. Linelyn G. Esteban and Prof. Arnel G. Doce putting the Amaranth leaves on the pan to dry it.



Prof. Edwin Jaimes B. Villafor creating his Amaranth Pasta.

EXTENSION SERVICES | HIGHLIGHTS

SIGMA

Some of the finished products of the trainees in Amaranth Pasta Making



Prof. Emelda R. Bacalangco, the trainer of this training, demonstrates how to make Rolled Bread with Vegetable Filling.



The trainees kneading the dough for their Rolled Bread.



SIGMA

Prof. Marie Anne J. Vallejo and Prof. Nilfa J. De la Paz two of the professors of CapSU Sigma joined the Training in MeMaCu Ice Cream Making.



The faculty and staff trainees working on their MeMaCu Ice Cream.

EXTENSION SERVICES | HIGHLIGHTS

SIGMA

The finished outputs of the Trainees after the Training in MeMaCu Ice Cream Making.



Prof. Roselyn P. Cabantud, Trainer of Bonsai Tree Making demonstrates how to make the Handcrafted Beadworks.



The outputs of the Trainees after the Trainers' Training in Bonsai Tree Making.

SIGMA

One of the best outputs during the Trainers' Training in Bonsai Tree Making because of its very unique landscape.



The close-up view of the landscape in the Bonsai Tree made by one of the trainees.



The outputs of the trainees in Macrame Bag and Slippers Making.

SIGMA

The outputs of the trainees in Macrame Plant Hanger Making.



Prof. Roselyn P. Cabantud, Trainer of Bonsai Tree Making demonstrates how to make the Handcrafted Beadworks.



The faculty trainees working on their Kalabana Catsup.

DAYAO

Different Trainings on Bangus Deboning and Canning, Meat Processing



The year 2022 has been a busy year for the Office of the Vice President for Administration and Finance. A number of infrastructure projects have been implemented, all intended to modernize Capiz State University and ensure that the campuses and satellite colleges become pandemic-resilient and future-proof learning hubs. The University continues to pursue judicious and prudent use of funds, either provided by the government or internally generated. As the institution advances its initiatives to become a sustainable academic institution, several income-generating projects are entered, which also provides additional source of revenue which are also used in funding the University's developmental initiatives.

ADVANCE INITIATIVES

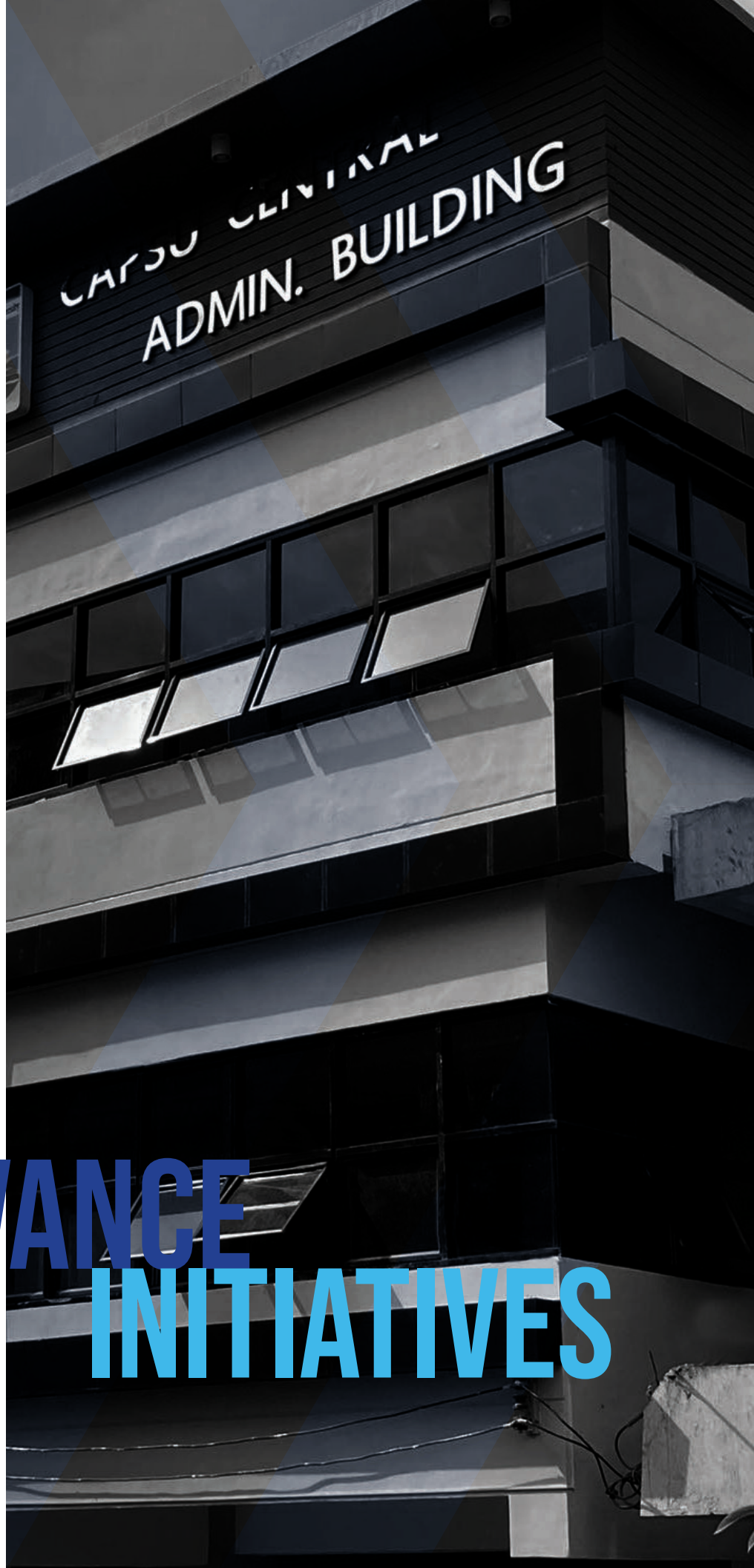

ADMINISTRATION AND GOVERNANCE

IMPLEMENTED PROJECTS

2021 CONTINUING PROJECTS

Project Title	Contract Price (Php)	Project Duration (No. of Months)	Date Started	Percentage of Accomplishment	Date of Completion (d/m/y)	Status	Contractor
<i>1. Renovation/ Expansion of Existing Building of CapSU Central Administration²</i>	13,489,884.22	330 CD	12/16/2019	100%	4/18/2022	Project completion was delayed due to pandemic (limited manpower mobility, community lock downs and material availability) and other issues and concerns such as unfavorable weather conditions, variation order implementation, and the at times uncooperative attitude of the project contractor. Though the project was COMPLETED, corresponding liquidated damages was charged.	Kris DB Construction and Supply
<i>2. Installation of Fire Works in the Renovation/ Expansion of Central Administration Building²</i>	2,199,620.00	75 CD	1/22/2021	100%	6/2/2022	COMPLETED, however, delayed and was charged with corresponding liquidated damages.	Kris DB Construction and Supply
<i>3. Renovation/ Expansion of Veterinary Medicine Academic Building, CAPSU Dumarao</i>	6,224,590.80	180 CD	5/14/2021	100%	6/6/2022	With approved time extension. Project completion was delayed due to the pandemic (community lock downs, limited manpower mobility). Also, bad weather condition caused delays. Though completion was delayed the project was COMPLETED and corresponding liquidated damages was charged.	BPJ Construction and Supply
<i>4. Reconstruction/ Rehabilitation of Industrial Technology Building, CAPSU Sigma</i>	2,888,991.64	180 CD	5/11/2021	100%	3/9/2022	With approved 10% variation order and time extension. Project completion was delayed due to the pandemic (community lock downs, limited manpower mobility). Also, bad weather condition caused delays. Though completion was delayed the project was COMPLETED and corresponding liquidated damages was charged.	7JL Hardware and construction Supplies

IMPLEMENTED PROJECTS

5. Rehabilitation/ Expansion of Poultry, CAPSU Burias	2,136,695.93	180	5/11/2021	100%	7/15/2022	The geographic location of the project rendered difficulty in the completion of the project to include the distance from the main power supply, the terrain and unfavorable weather conditions caused hauling of materials to the construction site difficult; COVID 19 pandemic had a way affected the project implementation. Granted time extension and 10% variation order; project completion was delayed (lapsed project) but now COMPLETED and charged with corresponding liquidated damages.	7JL Hardware and construction Supplies
6. Rehabilitation/ Expansion of Piggery	2,090,098.45	180	5/14/2021	100%	25/10/2022	The geographic location of the project rendered difficulty in the completion of the project to include the distance from the main power supply, the terrain and unfavorable weather conditions caused hauling of materials to the construction site difficult; COVID 19 pandemic had a way affected the project implementation. Granted time extension and 10% variation order; project completion was delayed (lapsed project) but now COMPLETED and charged with corresponding liquidated damages.	BPJ Construction and Supply
7. Rehabilitation/ Expansion of Growing Areas, CAPSU Burias	2,135,402.72	180	5/14/2021	100%	9/30/2022	The geographic location of the project rendered difficulty in the completion of the project to include the distance from the main power supply, the terrain and unfavorable weather conditions caused hauling of materials to the construction site difficult; COVID 19 pandemic had a way affected the project implementation. Granted time extensions and 10% variation order; project completion was delayed (lapsed project) but now COMPLETED and charged with corresponding liquidated damages.	BPJ Construction and Supply

ADMINISTRATION AND GOVERNANCE

8. Rehabilitation/ Expansion of Storage Building	350,385.89	60	5/11/2021	10%	10/2/2022	Requested for time extension due to hauling issues to project site; scarcity of materials and limited manpower mobility due COVID 19 pandemic. Granted time extension. A demand letter was sent to the contractor for project completion and had a response to complete the project. COMPLETED.	7JL Hardware and construction Supplies
9. Renovation/ Expansion of Material Recovery Facility (MRF), Roxas City Main	2,601,540.76	105 CD	11/15/2021	100%	12/27/2022	The required equipment (Garbage Conveyor Belt) was outsourced from China, however, due to the COVID 19 lockdown in Guangdong province, shipment was delayed thereby affecting project completion. Granted time extension; lapsed, COMPLETED.	J ¹⁴ Construction and Supply
10. Renovation of Graphic Arts Building, Roxas City Main	11,261,884.28	345 CD	11/15/2021	22%	On-going	Settlement of structural concerns and plan revision caused delay in the implementation/mobilization; granted 10 % variation (additional scopes of work) and time extensions. A work suspension was granted due to structural concerns. Return to work order was issued in Aug, 15, 2022. Work is in progress.	J ¹⁴ Construction and Supply
11. Expansion of Gabaldon Building (Annex 2) , Roxas City Main	2,773,024.87	180 CD	12/22/2021	100%	6/20/2022	COMPLETED	Rock 101 Construction and Supply
12. Expansion of Gabaldon Building (Annex 3) , Roxas City Main	3,998,221.17	180 CD	12/22/2021	100%	8/18/2022	COMPLETED	Rock 101 Construction and Supply
13. Installation of Fire Detection & Alarm System and Electrical Auxiliaries of the Renovation/ Expansion of New Central Administration Building, Capsu Roxas*	860,120.80	60 CD	7/29/2022	100%	10/4/2022	Completion date include the 5 days approved time extension; COMPLETED	FLT Enterprises
14. Tiling of Comfort Room of Industrial Technology Building at Sigma Satellite College 1	110,994.45	20 CD	10/4/2022	100%	10/19/2022	COMPLETED	MBM Construction

IMPLEMENTED PROJECTS

<i>15. Fabrication of storage Bins for the Renovation of Material Recovery Facility at CAPSU Roxas Main Campus1</i>	396,090.00		10/5/2022	100%	11/10/2022	COMPLETED	Giantwest Construction Corporation
<i>16. Construction of Pig Railings and Pathways at CAPSU Burias1</i>	287,224.35	60 CD	10/3/2022	100%	12/13/2022	COMPLETED	MBM Construction
<i>17. Civil and Electrical Works on the Ground Floor of Gabaldon Building (Annex 2) of CAPSU Roxas Main Campus1</i>	227,296.02	30 CD	10/7/2022	100%	11/17/2022	Granted a time extension of 5 CD; COMPLETED	Rock 101 Construction & Supply
<i>18. Construction of Student Lounge, Covered Footwalk, Provision for Logo and Signages, Steel Flat Form for Elevated Tank and Filtration1</i>	657,892.30	60 CD	11/5/2022	100%	12/14/2022	COMPLETED	JGC Construction

* Savings from equipment outlay 2021
 1 Savings from 2021 Building Outlay
 2 Funded from Internally Generated Fund

ADMINISTRATION AND GOVERNANCE

STATUS OF PROJECTS IMPLEMENTATION AS OF DECEMBER 31, 2022

2022 GAA FUNDED PROJECTS

Project Title	Contract Price (Php)	Project Duration (No. of Months)	Date Started	Percentage of Accomplishment	Date of Completion (d/m/y)	Status	Contractor
<i>1. Renovation/ Expansion of Central Admin Building Phase 2, Roxas City Main campus</i>	<i>6,486,691.20</i>	<i>180</i>	<i>July 15, 2022 (NTP); actual mobilization is July 26, 2022</i>	<i>85.00%</i>	<i>3/1/2023</i>	<i>On schedule; granted a 45 CD variation order.</i>	<i>Wingtip Builder, Inc.</i>
<i>2. Expansion/ Renovation of Physical Science Laboratory Building, Roxas City Main campus</i>						<i>On procurement process / Failed Bid</i>	
<i>3. Reconstruction/ Renovation/ Rehabilitation of Old Agri-Science Building, Mambusao Satellite College</i>						<i>On procurement process / Cancelled Bid subject to the submission of required documents (approved demolition permit from the LGU of Mambusao)</i>	
<i>4. Repair of Dadivas Auditorium, Roxas City Main Campus</i>						<i>On procurement process/ Cancelled bid subject to availability of funds considering that the project is a congressional insertion.</i>	

IMPLEMENTED PROJECTS



Renovation/Expansion of Veterinary Medicine Academic Building at CAPSU Dumarao



Rehabilitation/Expansion of Piggery (Gestating, Farrowing, Nursery Area) Project at CAPSU Burias

ADMINISTRATION AND GOVERNANCE

REHABILITATION/EXPANSION OF PIGGERY (GROWING AREA) AT CAPSU BURIAS



A paved path walk leading to the piggery project (growing area)



The growing area structure with the elevated storage tanks for the water supply of the project



REHABILITATION/EXPANSION OF POULTRY AT CAPSU BURIAS



A view of the poultry structure from a distance



The structure ready for stocking

STORAGE FACILITY AT CAPSU BURIAS



RECONSTRUCTION / REHABILITATION OF THE INDUSTRIAL TECHNOLOGY BUILDING AT CAPSU SIGMA



ADMINISTRATION AND GOVERNANCE

AN ONGOING PROJECT AT CAPSU ROXAS MAIN - THE RENOVATION/EXPANSION OF THE MATERIAL RECOVERY FACILITY (MRF) WITH THE FABRICATED STORAGE BINS



ANOTHER ONGOING PROJECT AT CAPSU ROXAS MAIN - THE RENOVATION OF THE GRAPHIC ARTS BUILDING



ADMINISTRATION AND GOVERNANCE

COMPLETED PHASE 1 OF THE EXPANSION OF THE GABALDON BUILDING ANNEX 2
(A 2-STOREY BUILDING WITH THE WALL, WINDOWS, AND ELECTRICAL WORKS ON THE GROUND FLOOR)



COMPLETED PHASE 1 OF THE EXPANSION OF THE GABALDON BUILDING ANNEX 3
(STRUCTURAL (COLUMNS, SLABS AND STAIRS) FOR A 3-STOREY BUILDING)



IMPLEMENTED PROJECTS

A PORTION OF THE RENOVATED BOARDROOM



The completed expansion of the Central Administration building that house the offices of the University President, the VP Admin and Finance, the Accounting dept, the Cashiering, Internal Audit, Budget, CAO (Finance and Administration), Board Secretary, HR, and Records.

ADMINISTRATION AND GOVERNANCE

PERSONNEL DEVELOPMENT



The faculty members and staff continued their pursuit towards professional growth and development. The opportunity of online seminars and trainings, as well as the resurgence of in-person conferences as the threat of COVID-19 pandemic waned down in the second half of 2022 have given our faculty members various options and opportunities to further their capabilities in their respective fields. With the strong support from the University Administration, our faculty members participated in a total of 1,589 local, regional, national, and international seminars, trainings, conferences, and other forms of professional development programs, benefitting a total of 1,391 attendees across the nine campuses and satellite colleges of the University.

ADMINISTRATION AND GOVERNANCE

GENDER AND DEVELOPMENT

The Administration continues to advocate for a gender sensitive and responsive University where diversity is celebrated and taken as an asset. Hence, the Office of the Gender and Development has laid a robust programming of activities throughout 2022 aimed at empowering every CAPSUnian regardless of gender, race, religion or any affiliation.



ADMINISTRATION AND GOVERNANCE

QUALITY MANAGEMENT SYSTEM

- On September 20-22, 2022, the 3-Day Virtual ISO 9001:2015 Continuous Training was conducted wherein Dr. Ingrid Manglapus served as the Course Tutor. This activity aimed to continually improve performances and competencies of CapSU Faculty, Officials and Personnel. The said activity was participated by the Campus Administrators, Satellite College Directors, Head of Offices of the Central Administration and University's Pool of Internal Auditors.
- Prior to ISO 9001:2015 First Surveillance Audit, an Internal Quality Audit Orientation and Last Minute Instruction was conducted on October 24, 2022 at the Conference Room of Roxas City Main Campus. It was attended by the University's Pool of Internal Auditors, Quality Management Representative (QMR), Deputy QMR, and the University Lead Auditor.
- The Office spearheaded the Internal Quality Audit on November 7-9 and November 14-16, 2022 in preparation of the ISO 9001:2015 First Surveillance Audit
- On December 2, 2022 the Management Review was conducted at the Conference Room of Roxas City Main Campus. The goal was to understand the results of IQA which being announced by every Internal Quality Auditor Team Leader assigned in different areas. Also, this is to address the major and minor NCs if there is any and to be prepared for the Corrective Action Plans (CARs). On the 6th page is the Quality Management System ISO 9001:2015 Management Review Minutes for SY 2022.
- The Onsite Quality Management System ISO 9001:2015 First Surveillance Audit (2nd Cycle) for Capiz State University was conducted on December 14-16, 2022. It was spearheaded by the SOCOTEC Certification Philippines, Inc. Auditors, Engr. Michael JordeMatundan was the Lead Auditor and Mr. Erwin Quinto as member. After the 3-Day Surveillance Audit, the SOCOTEC Lead Auditor announces that there is no minor and major conformity.



STATEMENT OF FINANCIAL POSITION

AS OF DECEMBER 31, 2022



ASSETS

Current Assets

Cash and Cash Equivalent	P 233,339,431.68
Receivables	115,618,316.55
Inventories	6,069,131.85
Other Current Assets	10,982,909.30
Total Current Assets	P 366,009,789.38

Non-Current Assets

Receivables	P 206,045,283.02
Property, Plant and Equipment	426,435,927.81
Biological Assets	24,250.00
Intangible Assets	3,314,356.65
Total Non-Current Assets	P 635,819,817.48

Total Assets

P1,001,829,606.86

LIABILITIES

Current Liabilities

Payables	P 35,487,838.01
Inter-Agency Payables	1,278,651.18
Intra-Agency Payables	153,491.73
Trust Liabilities	49,407,180.41
Other Payables	2,418,760.65
Total Current Liabilities	P 88,745,921.98

Non-Current Liabilities

Inter-Agency Payables	P 195,024,158.60
Intra-Agency Payables	12,006,879.69
Trust Liabilities	-
Total Non-Current Liabilities	P 207,031,038.29

Total Liabilities

P 295,776,960.27

Total Assets less Total Liabilities

P 706,052,646.59

NET ASSETS/EQUITY

Accumulated Surplus(Deficit)	P 706,052,646.59
Total Net Assets/Equity	P 706,052,646.59



FINANCIAL RESOURCES

STATEMENT OF PROFIT AND LOSS AS OF DECEMBER 31, 2022

REVENUE	2022
Service and Business Income	P 182,303,658.99
Total Revenue	P 182,303,658.99
Less: Operating Expense	
Personnel Services	P 587,540,709.06
Maintenance & Other Operating Expenses	211,943,676.24
Financial Expenses	156,344.36
Direct Cost	-
Non-Cash Expenses	30,191,637.37
Total Current Operating Expense	P 829,832,367.03
Surplus(Deficit) from Current Operations	(P 647,528,708.04)
Net Financial Assistance/Subsidy	P 673,763,600.84
Non Operating Income	2,361,047.09
Losses	
SURPLUS(DEFICIT) for the period	P 28,595,939.89



The mandate which is concerned with the identification, establishment, and business-like operation of income-generating projects (IGPs) is production. The concept of entrepreneurship dwells within the University operation of viable agro-fishery-industrial projects. These have even been widened and strengthened in light of the increasing financial problems being faced by SUCs. Income derived from these projects has dramatically augmented the financial capability of the University in carrying out its major institutional programs and activities. IGPs then must find a place in the entirety of the plans and programs of the University.

**AUGMENT
CAPABILITY**



IGP REPORT 2022

Capiz State University (CAPSU) is not only concerned with academics but also with other priorities which are believed complementary to the academic mandate of the institution. It has also diversified its mandate in response to the need for time. The University now focuses on a Quadro-dimensional mandate: instruction, research, extension, and production.

The mandate which is concerned with the identification, establishment, and business-like operation of income-generating projects (IGPs) is production. The concept of entrepreneurship dwells within the University operation of viable agro-fishery-industrial projects. These have even been widened and strengthened in light of the increasing financial problems being faced by SUCs. Income derived from these projects has dramatically augmented the financial capability of the University in carrying out its major institutional programs and activities. IGPs then must find a place in the entirety of the plans and programs of the University. Below is the University IGP net income by campus:

IGP NET INCOME BY CAMPUS

CAMPUS	NET INCOME
BURIAS	(52,884.36)
PONTEVEDRA	1,054,617.56
ROXAS	251,620.84
DAYAO	(351,974.86)
SIGMA	296,510.68
DUMARAO	13,003.00
PILAR	30,907.25
TAPAZ	(3,655.50)
MAMBUSAO	28,931.00
CENTRAL OFFICE	207,855.92
TOTAL	1,474,931.53

In Fiscal Year 2022, the income-generating projects earned PHP 1,474,931.53 on the nine campuses, including the central office's printing press. Pontevedra campus got the highest income, followed by Sigma satellite college, Roxas City main campus, and the printing press of Central Administration. Dumarao, Pilar, and Tapaz satellite college got an income of below a hundred thousand. In contrast, Burias Dayao satellite College Campus and Tapaz satellite college got below the positive income. These three campuses suffer from low income due to uncontrolled environmental phenomena and the renovation of facilities such as fishpond dikes, construction and renovation of stalls, and repair and maintenance of equipment and facilities.

NET INCOME BY COMMODITIES

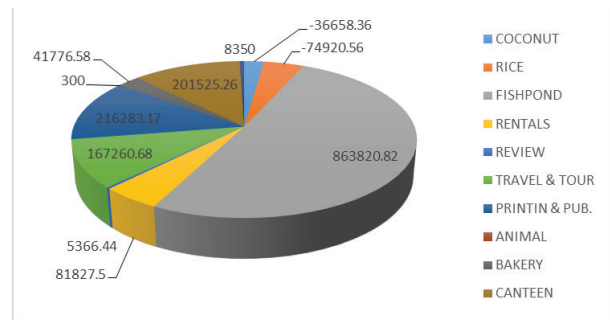

The increase of PHP 1,474,931.53 in commodities was generated from various IGPs such as Fishponds, Printing Press, Canteen Travel & Tour, Bakery Rentals, Animal Production, and Review center. The realization of the targets shall spin-off from agro-industrial and aquaculture to include rental services and other business ventures towards a sustainable income-generating project.

The University Business Affairs Office will continue to strategize to improve the existing IGPs of the University, like the preparation of an Economic Development Plan that shall serve as the overarching plan towards the development of sustainable and multi-product projects that will significantly contribute to the SUCs' revenue streams.

SUMMARY OF BOARD RESOLUTIONS



SUMMARY OF BOARD RESOLUTIONS

20TH SPECIAL FEBRUARY 4, 2022 (VIA ZOOM MEETING)	6 APPROVED				
21ST SPECIAL AUGUST 25, 2022	13 APPROVED	2 DEFERRED			
22ND SPECIAL SEPTEMBER 16, 2022	6 APPROVED				
23RD SPECIAL SEPTEMBER 16, 2022	2 APPROVED				
70TH REGULAR APRIL 27, 2022	14 APPROVED	3 GRANTED	1 DEFERRED	3 NOTED	1 CONFIRMED
71ST REGULAR JULY 8, 2022	13 APPROVED	3 GRANTED	1 NOTED	1 CONFIRMED	
72ND SPECIAL DECEMBER 4, 2022	12 APPROVED	2 GRANTED	3 DEFERRED	2 CONFIRMED	

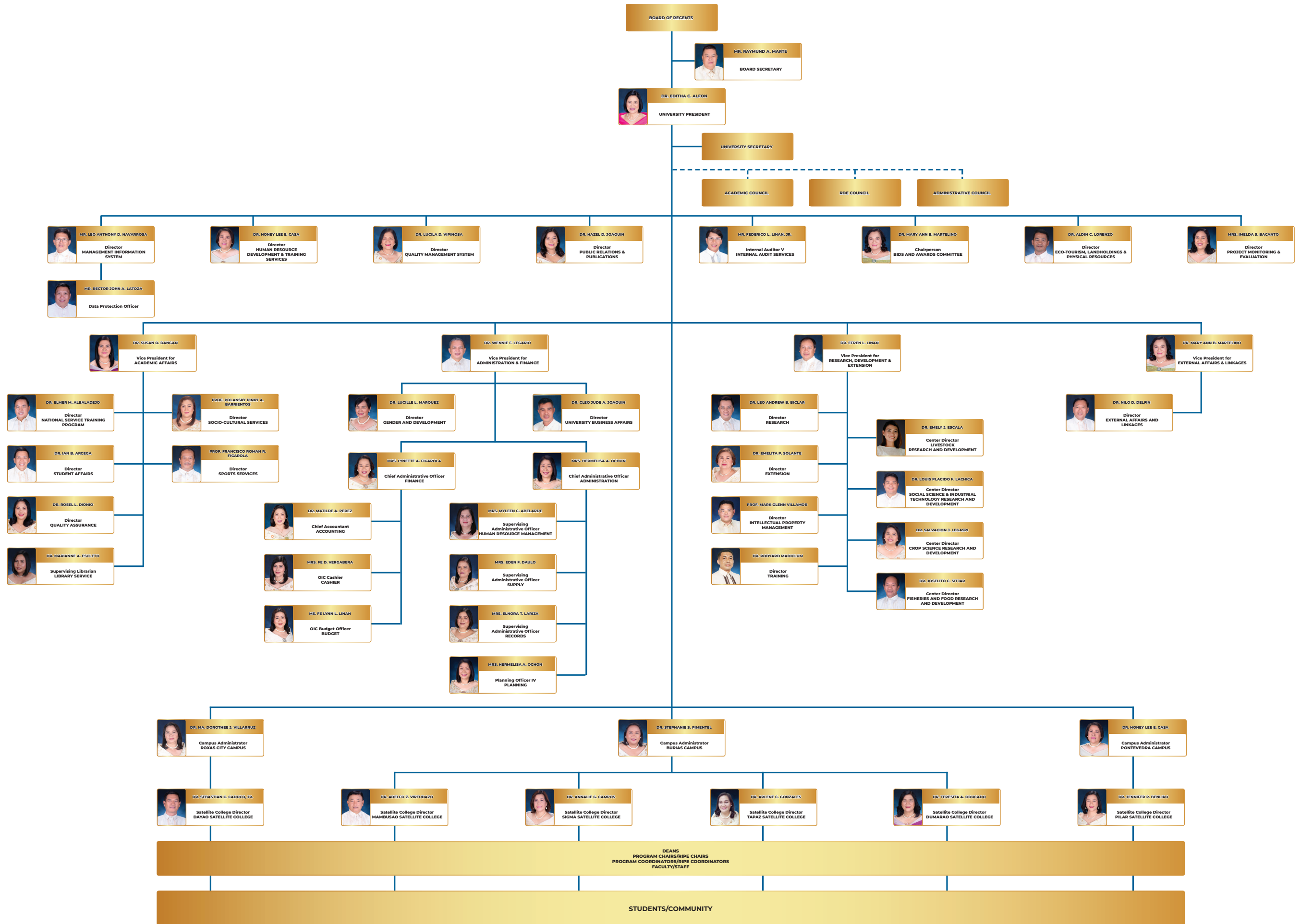



ORGANIZATIONAL STRUCTURE

CAPSU BOARD OF REGENTS

REGENT J. PROSPERO DE VERA, III
Chairperson, CapSU BOR

REGENT EDITHA ALFON
Vice-Chairman/CapSU President

REGENT JOEL VILLANUEVA
Chairperson, Senate Committee on Education, Arts & Culture

Represented by:

DR. EDWIN CHINEL MONARES

REGENT MARK GO
Chair, Higher and Technical Education

Represented by:

ATTY. VICENTE ATLAS CATALAN

REGENT MEYLENE ROSALES
NEDA Regional Director

REGENT ROWEN GELONGA
DOST Regional Director, Region VI

REGENT REMELYN RECOTER
DA Regional Director, Region VI

REGENT ABUNDIO BALGOS
Private Sector Representative

REGENT MARICEL JARENCIO
Private Sector Representative

REGENT FORTUNATO AZARCON
Alumni Federation President

REGENT LIDA CORCINO
Faculty Federation President

REGENT JSAH MYRL HUMPAY
SSC Federation President

MR. RAYMUND A. MARTE
Board Secretary V

CAPIZ STATE UNIVERSITY

KEY OFFICIALS

DR. EDITHA C. ALFON
UNIVERSITY PRESIDENT

DR. SUSAN O. DANGAN
VP FOR ACADEMIC AFFAIRS

DR. WENNIE F. LEGARIO
VP FOR ADMINISTRATION & FINANCE

DR. EFREN L. LINAN
VP FOR RESEARCH, DEVELOPMENT & EXTENSION

DR. MARY ANN B. MARTELINO
VP FOR EXTERNAL AFFAIRS & LINKAGES

CAMPUS ADMINISTRATORS

ROXAS CITY MAIN CAMPUS
PONTEVEDRA CAMPUS
BURIAS CAMPUS

DR. MA. DOROTHEE J. VILLARRUIZ
DR. HONEY LEE E. CASA
DR. STEPHANIE S. PIMENTEL

SATELLITE COLLEGE DIRECTORS

DAYAO SATELLITE COLLEGE
PILAR SATELLITE COLLEGE
DUMARAO SATELLITE COLLEGE
SIGMA SATELLITE COLLEGE
MAMBUSAO SATELLITE COLLEGE
TAPAZ SATELLITE COLLEGE

DR. SEBASTIAN C. CADUCO, JR.
DR. JENNIFER B. BENLIRI
DR. MARIE JEAN P. PENSON
DR. ANNALIE G. CAMPOS
DR. ADELFO Z. VIRTUDAZO
PROF. ARLENE GONZALES

SUPPORT STAFF

BOARD SECRETARY
CHIEF ADMINISTRATIVE OFFICER (FINANCE)
CHIEF ADMINISTRATIVE OFFICER (ADMINISTRATION)/BAC CHAIRMAN
CHIEF ACCOUNTANT
INTERNAL AUDITOR
PLANNING OFFICER
DIRECTOR, PROJECT MONITORING AND EVALUATION
DIRECTOR, ECO-TOURISM, LANDHOLDINGS AND PHYSICAL RESOURCES
DIRECTOR, UNIVERSITY BUSINESS AFFAIRS
DIRECTOR, EXTERNAL AFFAIRS AND LINKAGES
DIRECTOR, MANAGEMENT INFORMATION SYSTEM
DIRECTOR, QUALITY MANAGEMENT SYSTEM
DIRECTOR, QUALITY ASSURANCE/CURRICULUM PLANNING AND ACCREDITATION
DIRECTOR, NATIONAL SERVICE TRAINING PROGRAM
DIRECTOR, PUBLIC RELATIONS AND PUBLICATIONS
DIRECTOR, GENDER AND DEVELOPMENT
DIRECTOR, STUDENT AFFAIRS
DIRECTOR, SPORTS SERVICES
DIRECTOR, SOCIO-CULTURAL SERVICES
DIRECTOR, HUMAN RESOURCE DEVELOPMENT AND TRAINING SERVICES
OIC, CASHIER
OIC, BUDGET
SAO, HUMAN RESOURCE MANAGEMENT
SAO, RECORDS
SUPPLY OFFICER
SUPERVISING LIBRARIAN, LIBRARY SERVICES

MR. RAYMUND A. MARTE
MRS. LYNETTE A. FIGAROLA
MRS. VICKY R. DURANA
DR. MATILDE A. PEREZ, CPA
MR. FEDERICO L. LINAN, JR.
MRS. HERMELISA A. OCHON
MRS. IMELDA S. BACANTO
DR. JOHNNY D. DARIAGAN
DR. STEPHANIE S. PIMENTEL
DR. AMEL L. MAGALLANES
MR. LEO ANTHONY D. NAVARROSA
DR. LUCILA D. VIPINOSA
DR. ROSEL L. DIONIO
DR. ELMER M. ALBALADEJO
DR. HAZEL D. JOAQUIN
DR. LUCILLE L. MARQUEZ
DR. IAN B. ARCEGA
PROF. FRANCISCO ROMAN R. FIGAROLA
PROF. POLANSKY PINKY A. BARRIENTOS
DR. HONEY LEE E. CASA
MRS. FE D. VERGABERA
MS. FE LYNN L. LINAN
MS. MARILYN D. BORNALES
MRS. ELDORA T. LARIZA
MRS. EDEN F. DAULO
DR. MARIANNE A. ESCLETO

RDE DIRECTORS

RESEARCH
EXTENSION
INTELLECTUAL PROPERTY MANAGEMENT

DR. LEO ANDREW B. BICLAR
DR. EMELITA P. SOLANTE
ENGR. EFREN L. LINAN

R & D CENTER DIRECTORS

CROP SCIENCE, RESEARCH AND DEVELOPMENT CENTER (CSRDC)
FISHERIES AND FOOD RESEARCH DEVELOPMENT CENTER (FFRDC)
LIVESTOCK RESEARCH AND DEVELOPMENT CENTER (LRDC)
SOCIAL SCIENCE AND INDUSTRIAL TECHNOLOGY RESEARCH DEVELOPMENT CENTER (SSITRDC)

DR. SALVACION J. LEGASPI
DR. JOSELITO C. SITJAR
DR. MARYNETH B. BARIOS
DR. LOUIS PLACIDO F. LACHICA

FACILITATIVE STAFF

MRS. EMILY P. LAUNIO
MRS. MARY JANE L. ARROYO
ENGR. NIÑA L. OBEJA
ENGR. NICOLAS A. BRAÑA, III
ENGR. ALAN D. CAMPOS
MR. RECTOR JOHN A. LATOZA
MRS. MARIBEL B. TUANTE

MR. LEO V. MARABE
MRS. AMELIA F. MOISES
MRS. FE D. VERGABERA
MR. ROBERT G. ASSIN
MRS. AMY JOY M. DAPILAGA
MRS. NORLIE L. OVERENCIO
MR. RAUL J. FRANCISCO

MR. JULIUS CEZAR O. DELA CRUZ
MRS. EDNA S. GENTOLEA
MRS. RAE NORREIN S. LEDESMA
MR. BERNIE A. SUPE
MR. JOSELITO T. LARIZA
MR. CEFERINO L. LIZADA
MR. ANTONIO M. BUÑI

MRS. MICHELLE C. ACEVEDO
MR. JULIUS D. DANGAN
MR. JOSELITO L. LAVA
MR. REX D. PARUM
MR. KEVIN D. BESANA
MR. RALPH GERARD M. CADIZ
MS. IVY BERMIO



CONSULTANTS

DR. EDITHA C. ALFON
University President

DR. SUSAN O. DANGAN
Vice President for Academic Affairs

DR. WENNIE F. LEGARIO
Vice President for Administration and Finance

DR. EFREN L. LINAN
Vice President for Research, Development and Extension

DR. MARY ANN B. MARTELINO
Vice President for External Affairs and Linkages

PRODUCTION TEAM

Dr. Susan O. Dangan
Dr. Rosel L. Dionio
Prof. Christian George F. Acevedo
Ralph Gerard M. Cadiz
Mia R. Degala
Kristine Joy A. Tamayo
Reno L. Ocampo
Raul J. Francisco
Renante B. Alaban
Romel A. Gomez
Rosemarie V. Francisco

CAPIZ STATE UNIVERSITY

Fuertes Drive • Roxas City, Philippines 5900 • Tel./Fax: (056) 271-8101 • E-mail: info@capisu.edu.ph
Capiz State University is accredited by Accrediting Agency of Chartered Colleges and Universities of the Philippines, Inc. (AACUP) and the Philippine Association of State Universities and Colleges (PASUC) and Agricultural Colleges Association of the Philippines (ACAP).
website: www.capisu.edu.ph • email address: admin@capisu.edu.ph



PRINTED BY:

CAPIZ STATE UNIVERSITY
Corner Fuertes Drive, Roxas City



CAPIZ STATE UNIVERSITY
ADMIN. BUILDING

MOVING FORWARD

CAPIZ STATE UNIVERSITY
ANNUAL REPORT

2022 EDITION